

0200

- ▲ **Slotted-type boxes** consist of basically one piece with a glued, stitched or taped manufacturers joint and top and bottom flaps. They are shipped flat, ready to use and require closing using the flaps provided.
- ▲ **Caisses à rabats**, d'une seule pièce, avec joint d'assemblage collé, agrafé ou à bande gommée. Elles sont livrées à plat, prêtes à l'emploi et nécessitent d'être fermées.
- ▲ **Faltschachteln (Faltkisten)** bestehen in der Regel aus einem Stück mit einer durch Laschenklebung, Drahtheftung bzw. Klebestreifen verbundenen Fabrikante sowie Deckel- und Bodenklappen. Sie werden flach zusammengefaltet versandt, sind

gebrauchsfertig und werden anhand der Klappen verschlossen.

- ▲ **Case a falde**: Scatole americane costruite in un singolo pezzo base con la giunta incollata, cucita o nastrata e con falde superiori e inferiori. Sono consegnate stese, pronte da utilizzare e richiedono chiusura tramite le apposite falde.
- ▲ **Cajas de tipo ranurado**: consisten básicamente en una pieza con juntas de fabricación encolada, cosida o pegada con cinta y solapas superiores e inferiores. Se despachan extendidas en un plano, listas para su uso y se cierran utilizando las solapas superiores e inferiores.

0200 M/A

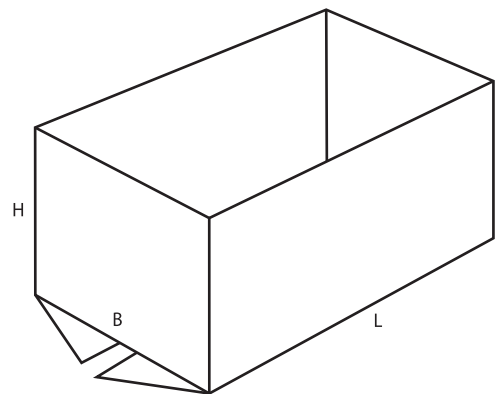
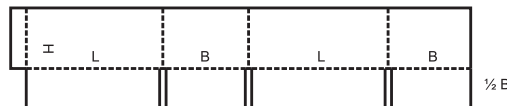

0201 M/A

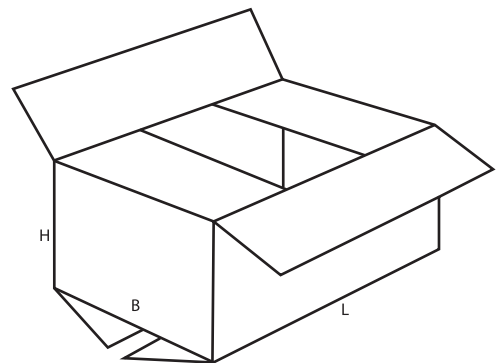
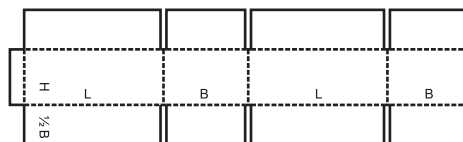

0202 M/A

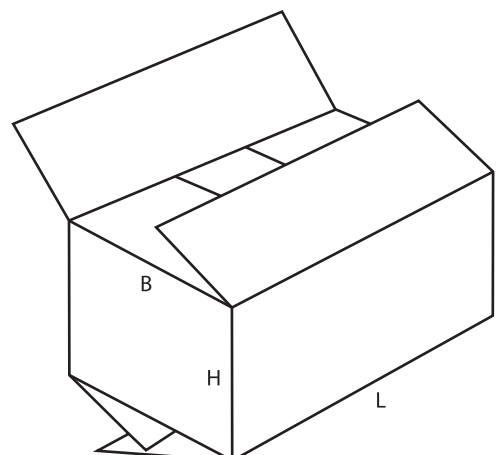
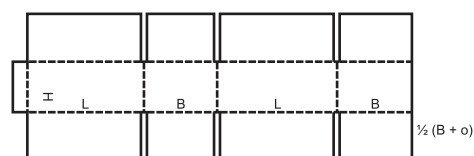

0203

M/A

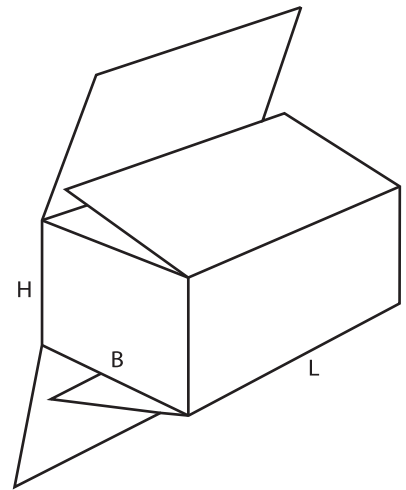
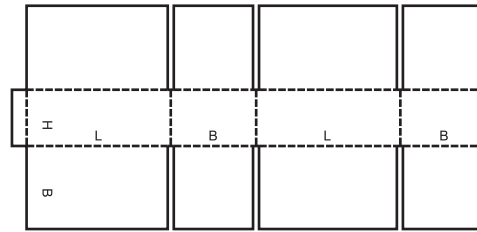

0204

M/A

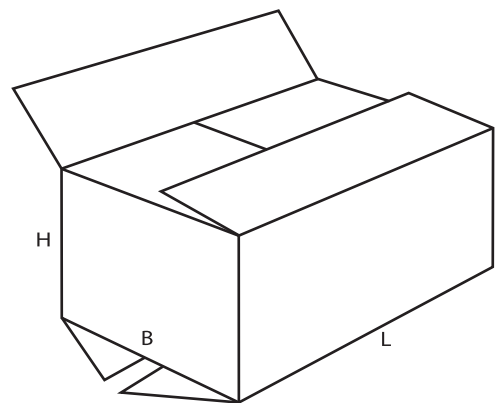
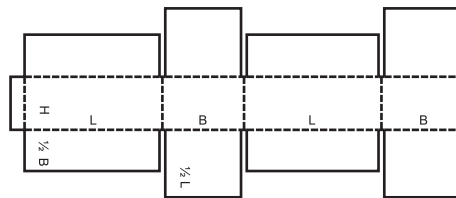

0205

M/A

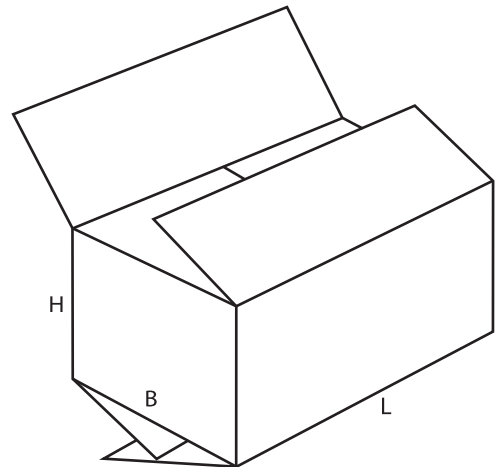
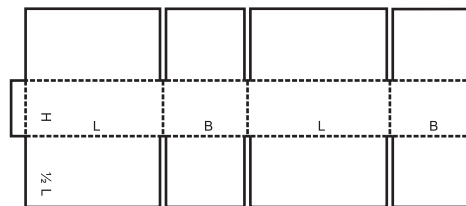

0206

M/A

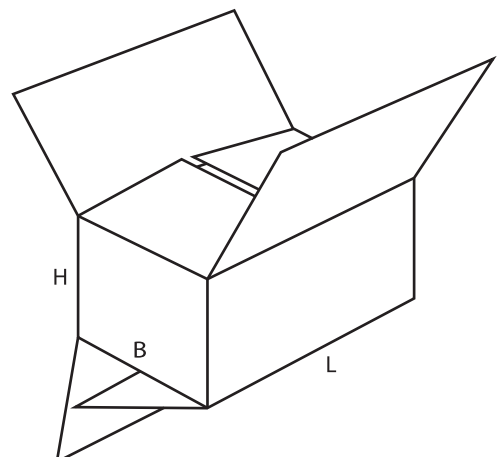
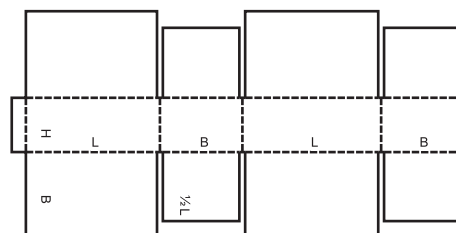

0207

M

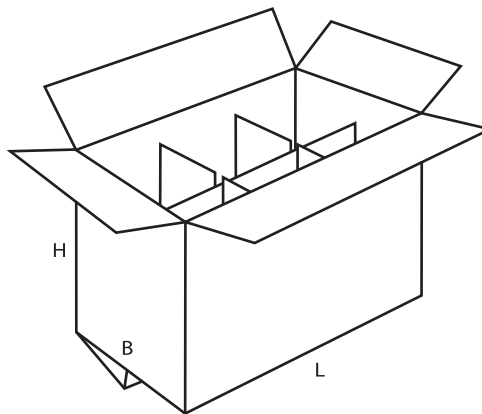
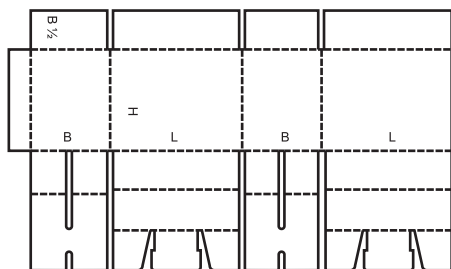

0208

M

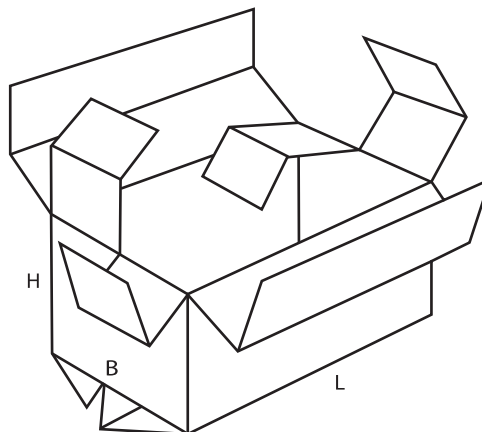
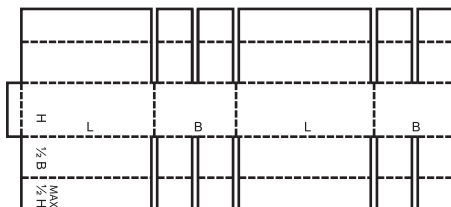

0209

M/A

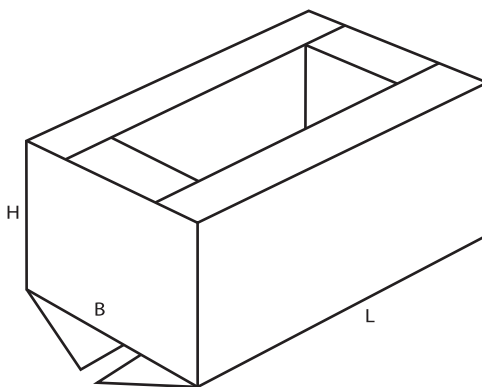
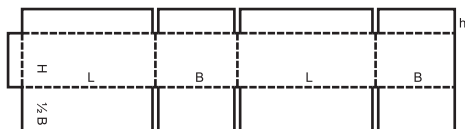

0210

M

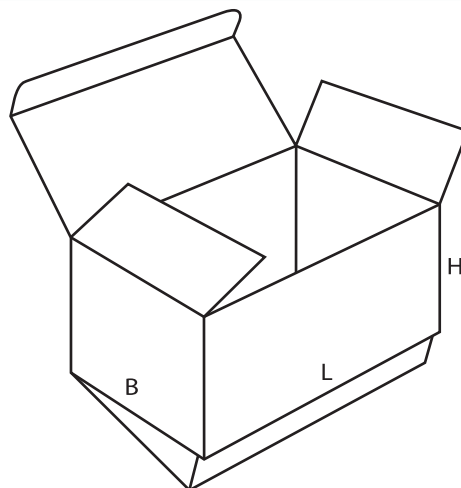
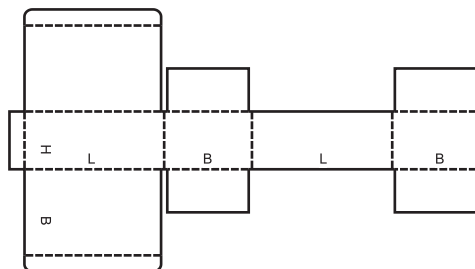

0211

M

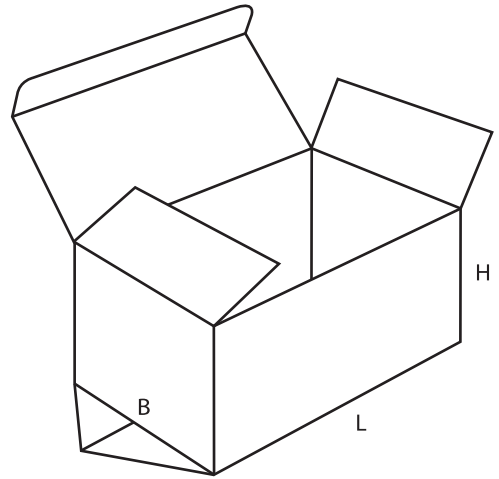
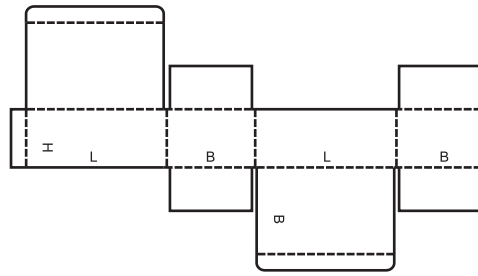

0212

M/A

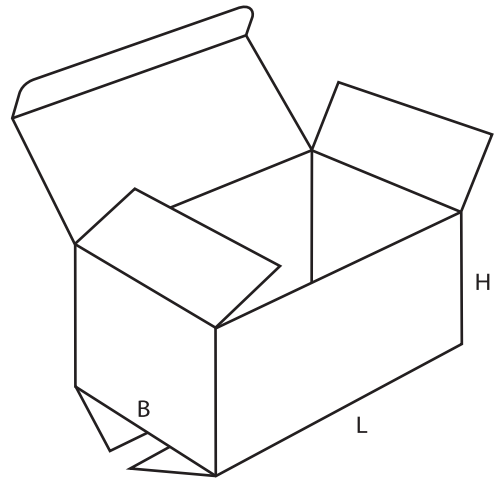
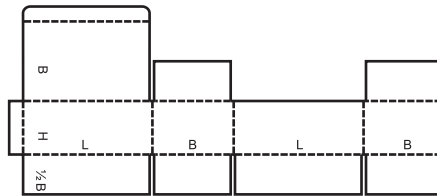

0214

M

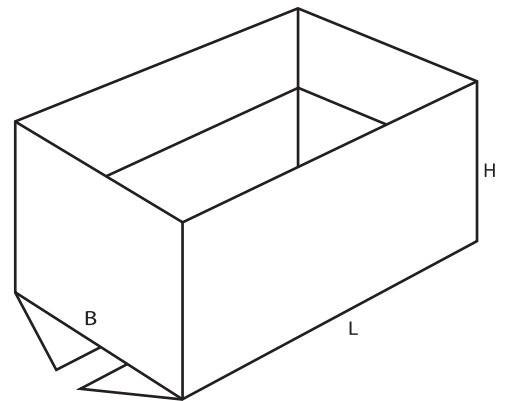
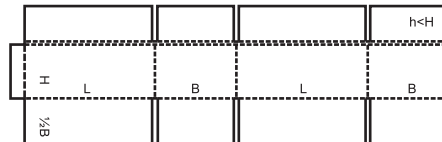

0215

M

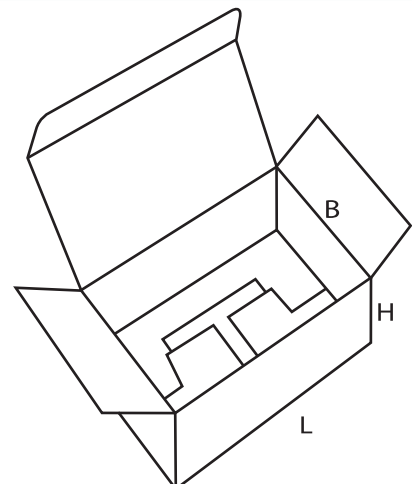
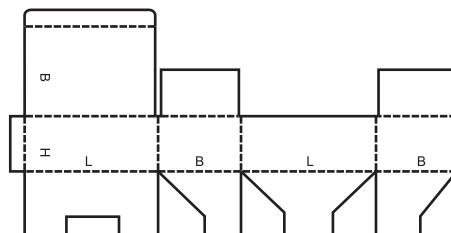

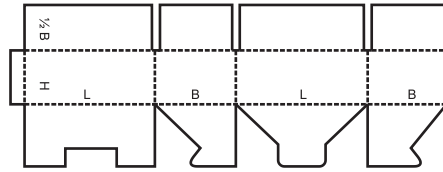
0216**M**

closure of top can be automated
 la fermeture du dessus peut être automatisée
 Derverschluss des aufsatzes kann automatisiert werden

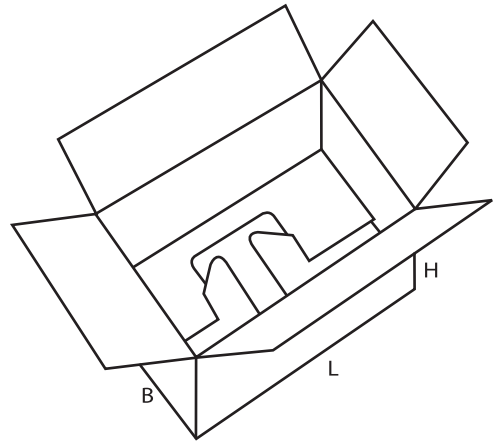
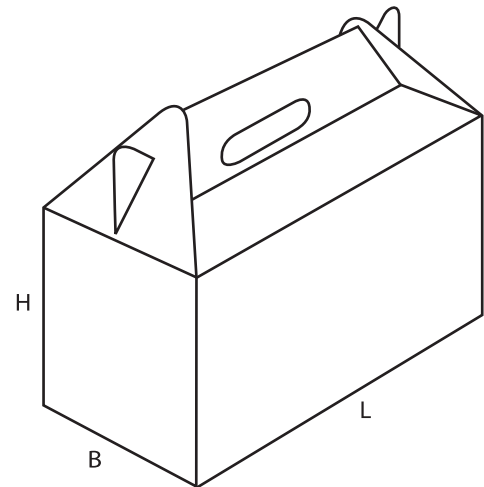
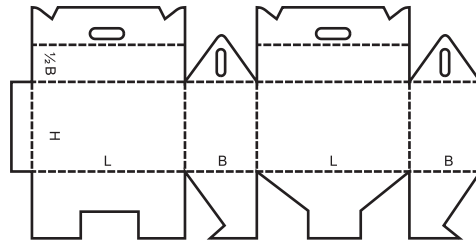
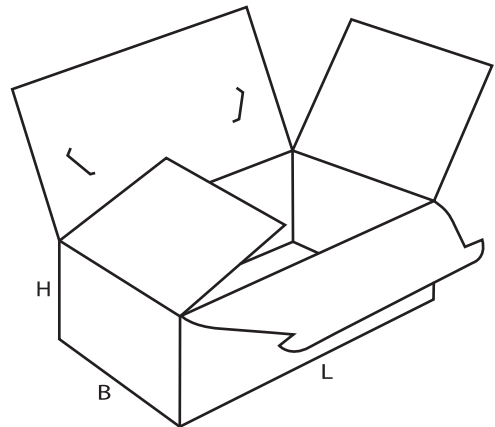
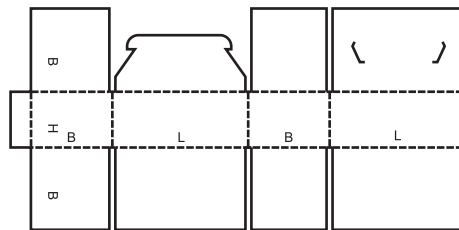
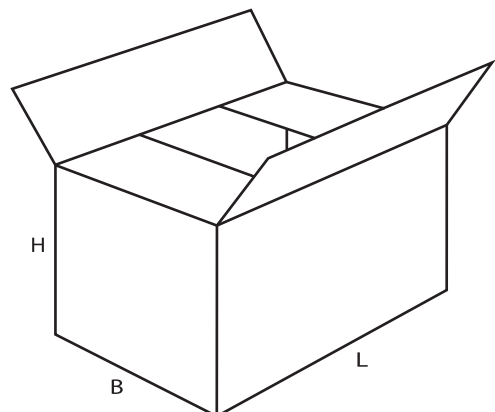
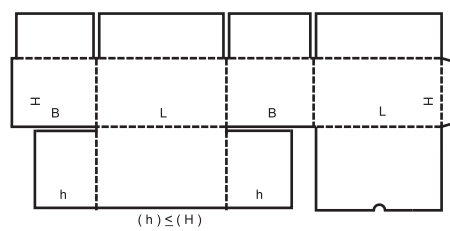
**0217****M****0218****M****0225****M**

0226

M

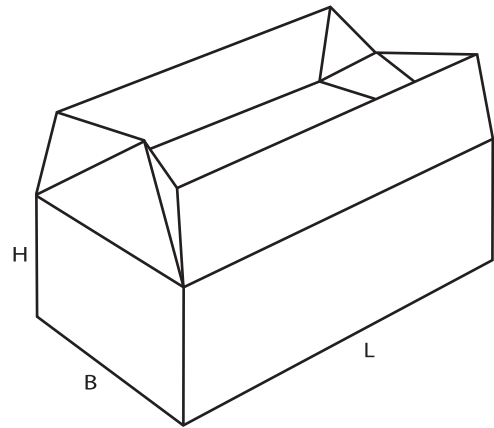
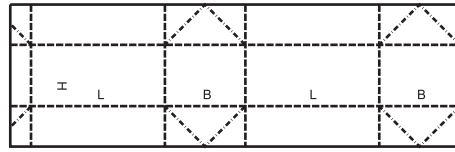

0227

M

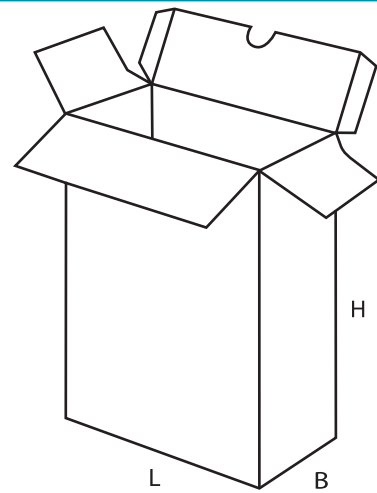
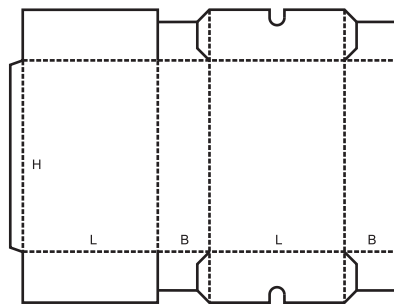

0228

M/A

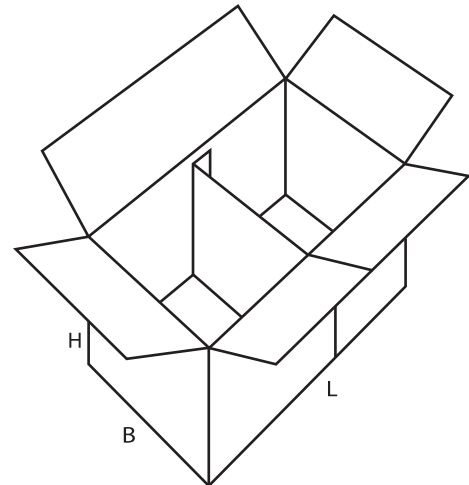
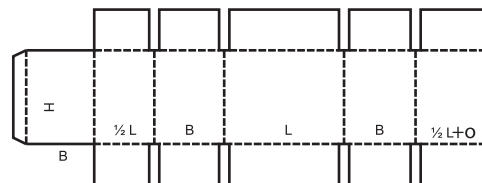

0229

M

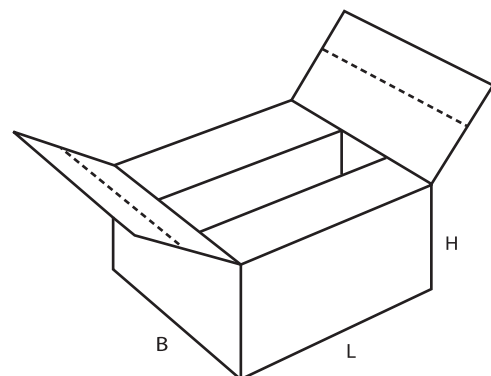
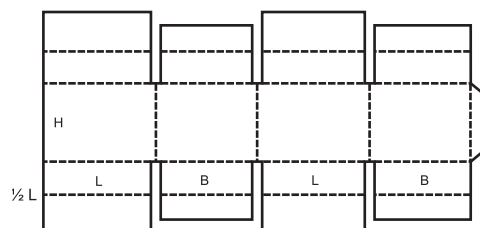

0230

M/A

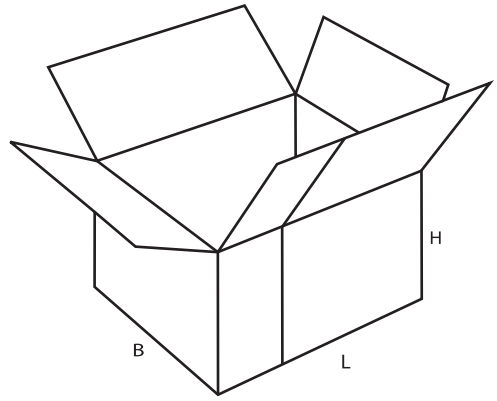
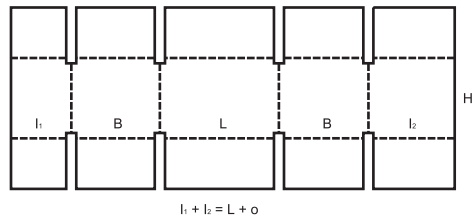

0231

M/A

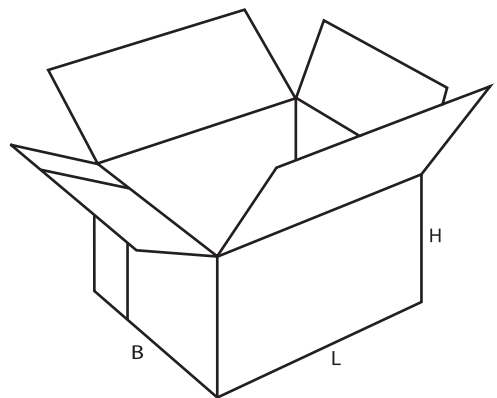
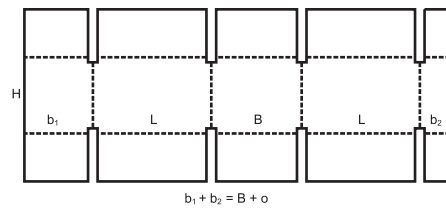

0300

- ▲ **Telescope-type** boxes consist of more than one piece and are characterised by a lid and/or bottom telescoping over the body of the box.
- ▲ **Caisses télescopiques** constituées par plus d'une pièce et caractérisées par un couvercle et/ou un fond séparé se glissant sur le corps de la caisse.
- ▲ **Deckelschachteln (Stülp-schachteln)** bestehen aus zwei oder mehr Teilen. Ein Oberteil (Deckel) wird über ein Unterteil (Boden) gestülpt oder beide über einen Rumpf.

- ▲ **Casse telescopiche:** Scatole telescopiche costituite da più di un componente e caratterizzate da un coperchio e/o fondo che scorre esternamente al corpo della scatola.
- ▲ **Cajas telescópicas:** fabricada con más de una pieza, se caracterizan por una tapa y/o fondo que se desliza sobre el cuerpo de la caja.

0300

M/A

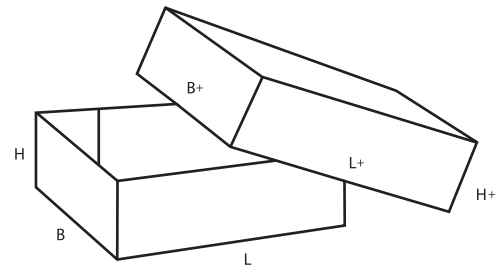
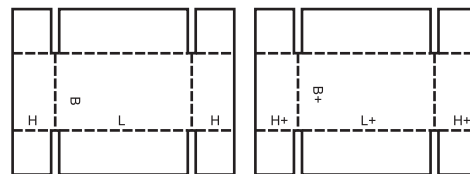

0301

M/A

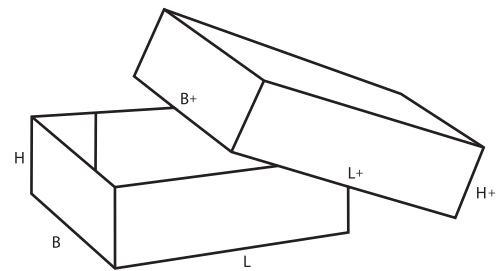
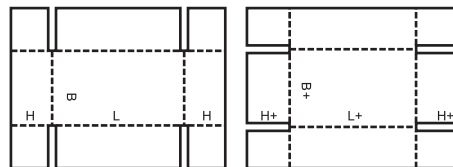

0302

M

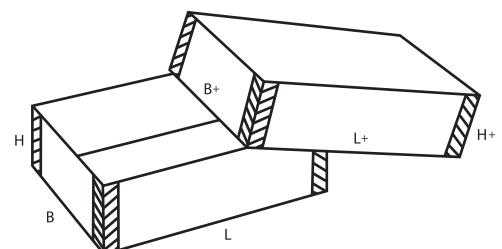
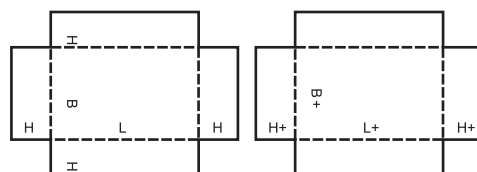

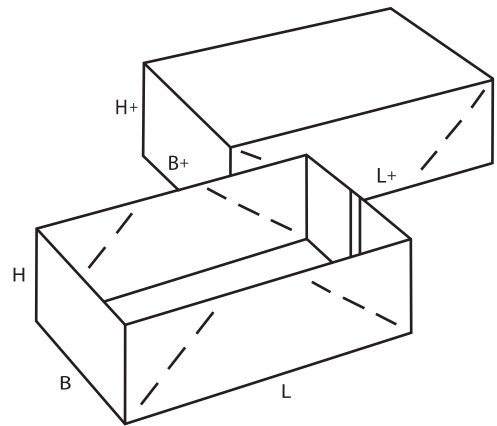
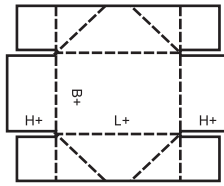
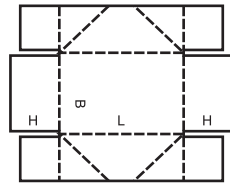
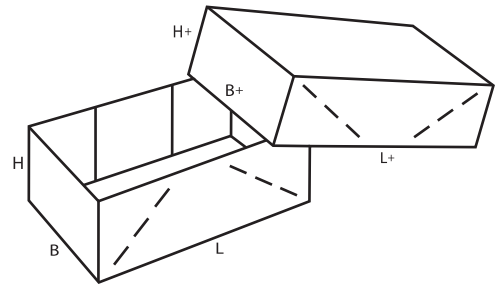
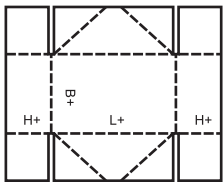
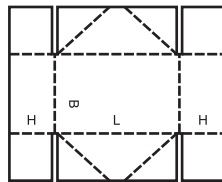
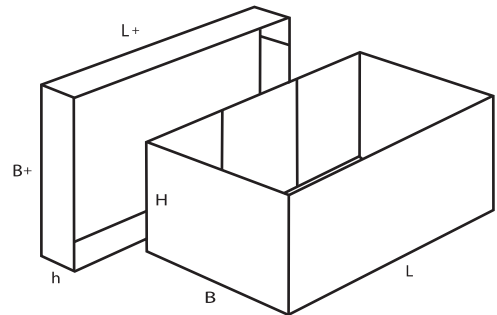
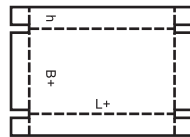
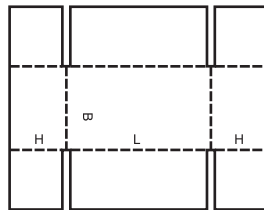
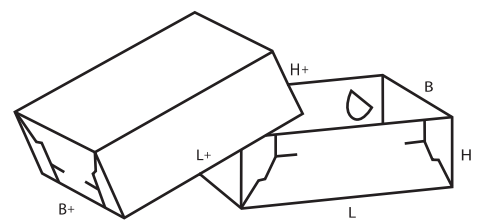
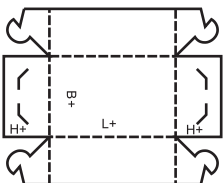
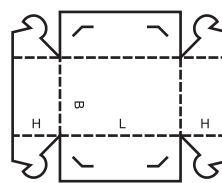
0303**M****0304****M****0306****M/A****0307****M**

0308

M

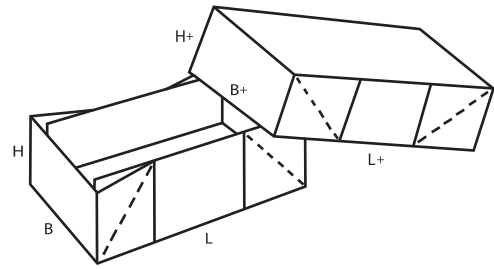
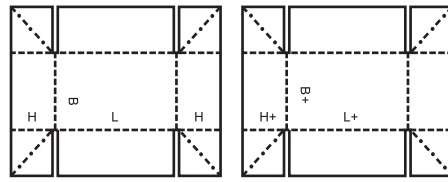

0309

M

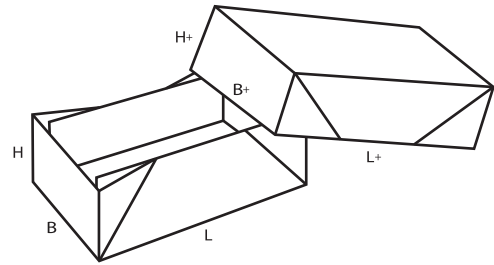
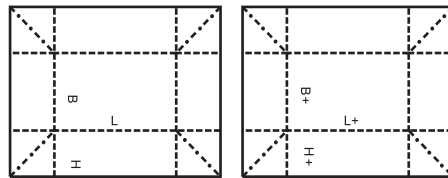

0310

M+A

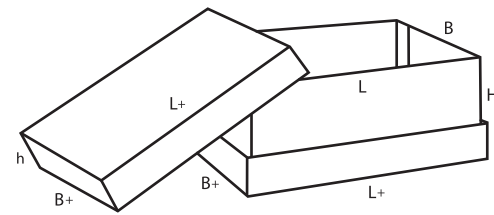
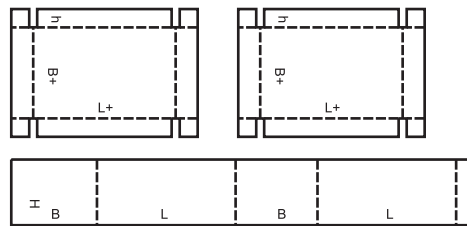

0312

M/A

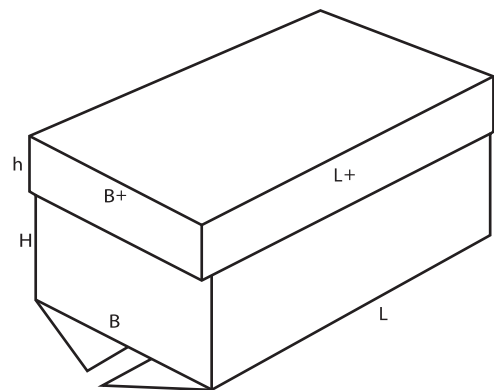
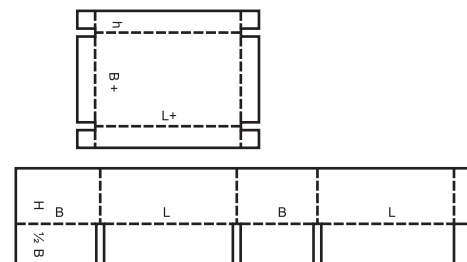

0313

M/A

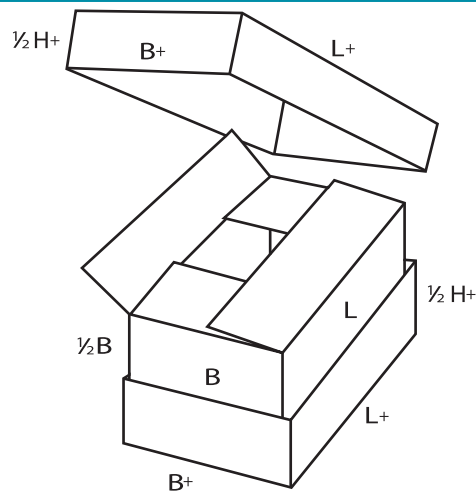
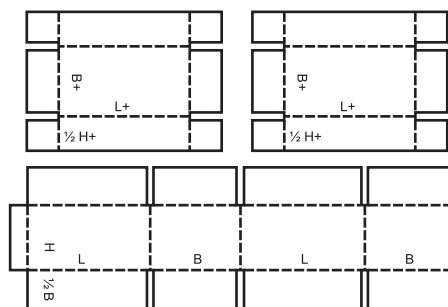

0314

M

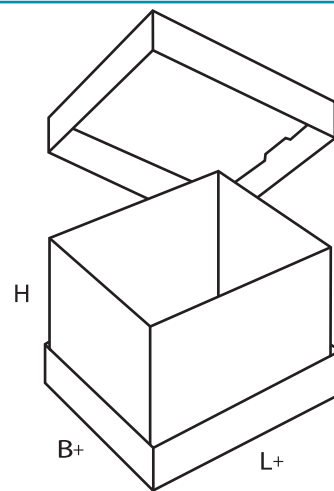
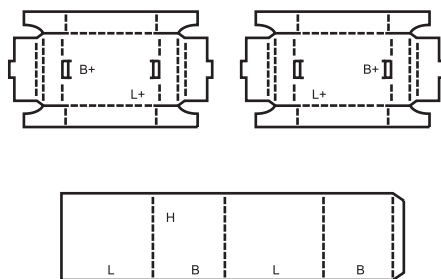

0320

M/A

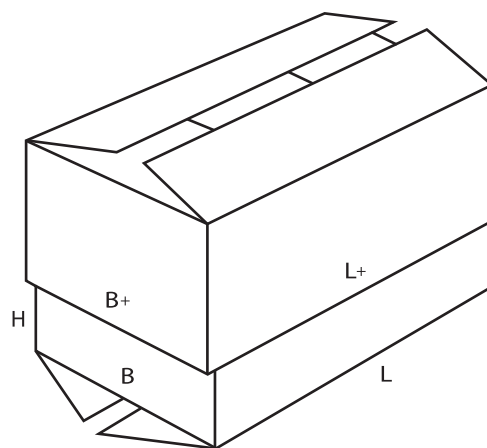
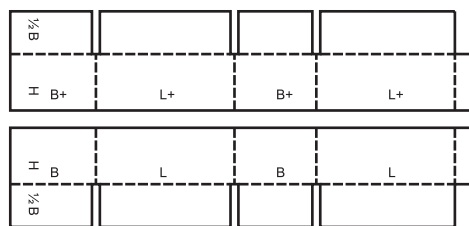

0321

M

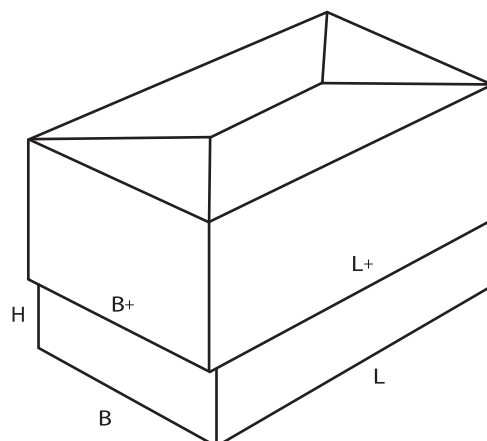
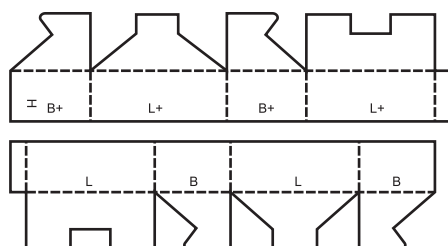

0322

M

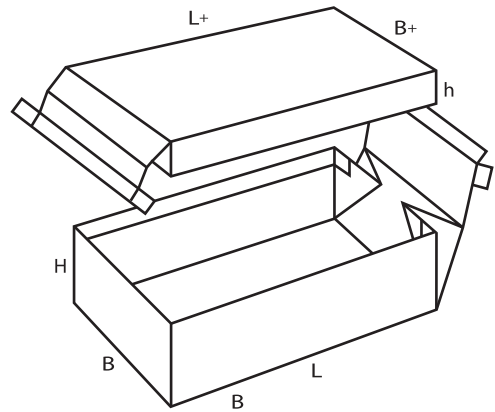
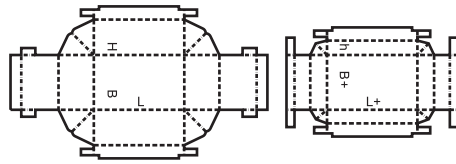

0323

M

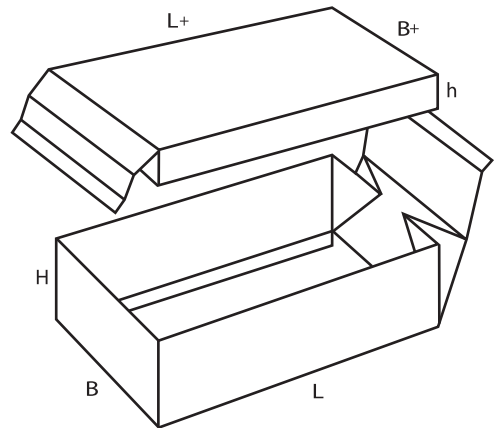
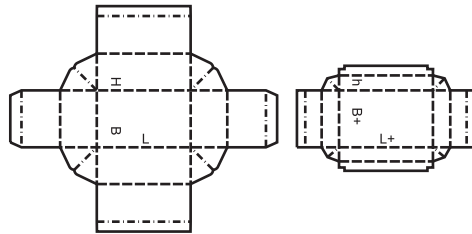

0325

A

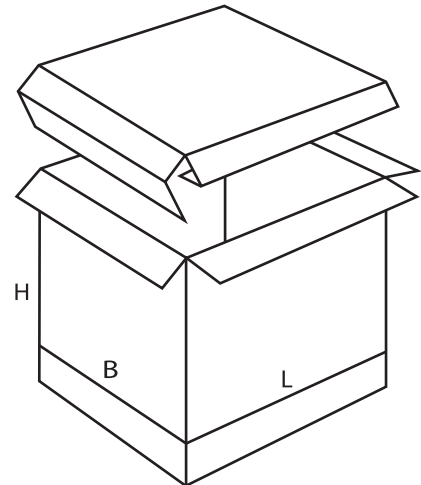
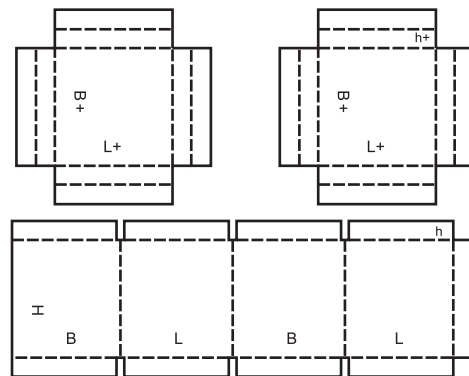

0330

M/A

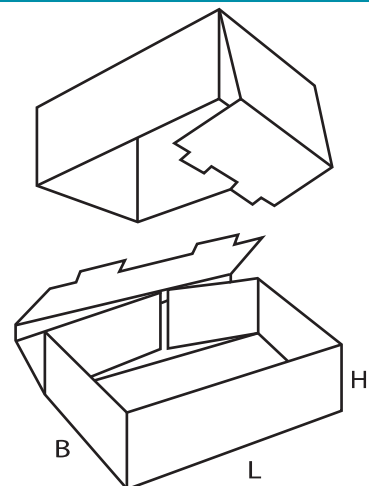
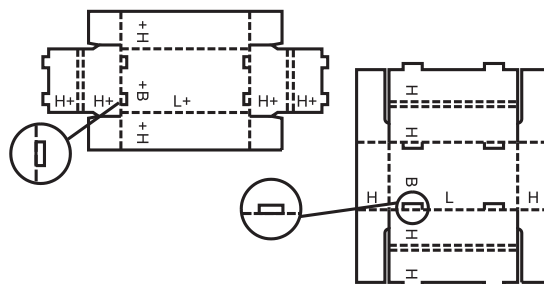

0331

M/A

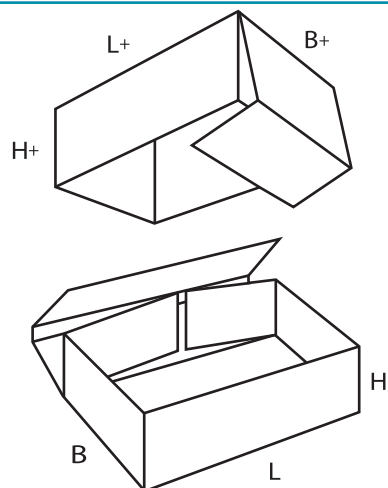
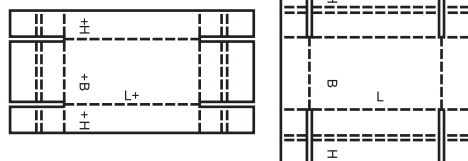

0350

M

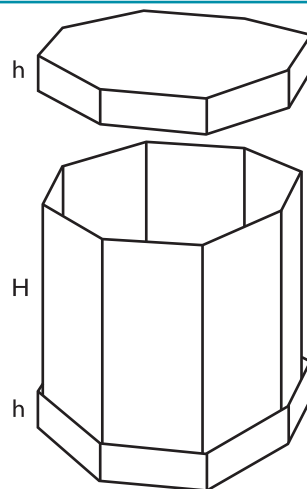
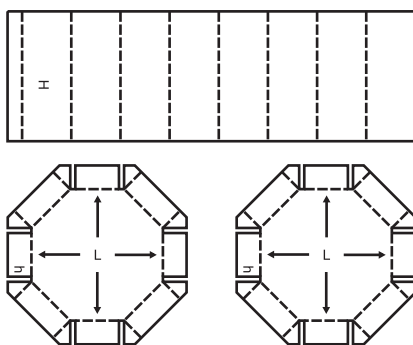

0351

M/A

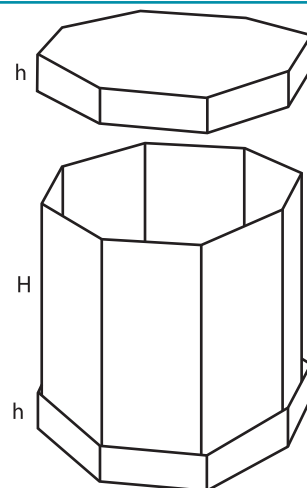
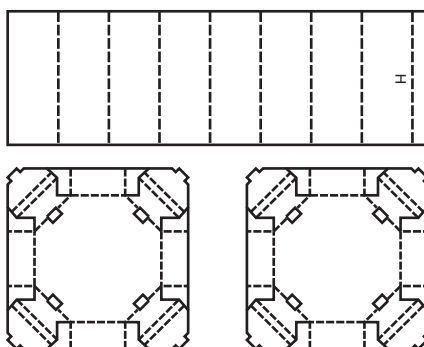

0352

M/A

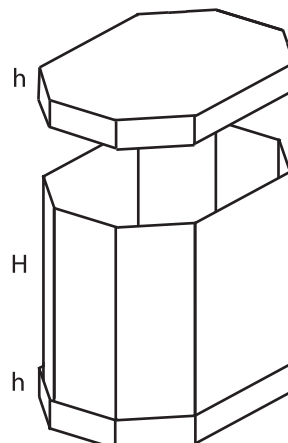
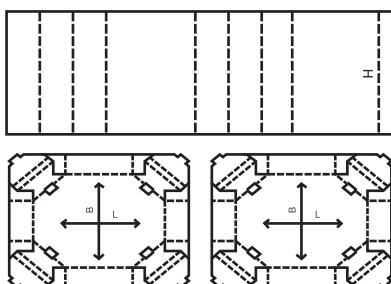

0400

- Folder-type boxes** and trays usually consist of only one piece of board. The bottom of the box is hinged to form two or all side walls and the cover. Locking tabs, handles, display panels etc., can be incorporated in some designs.
- Enveloppes et plateaux** en général constitués d'une seule pièce, montés sans agrafage ni bande gommée, et pouvant comporter des éléments de verrouillage, d'encliquetage, et des poignées.
- Falzhüllen und Trays** bestehen im allgemeinen aus einem Zuschnitt. Zwei oder alle Seitenwände und der Deckel sind am Boden angelenkt. Sperrvorrichtungen, Handgriffe, Verkaufsteller usw. können bei dieser

Ausführungsart mit vorgesehen werden.

- Scatole pieghevoli e vassoi:** Contenitori e vassoi formati normalmente dalla piegatura di un pezzo di cartone. Il fondo del contenitore è delimitato da pieghe in modo da formare due o tutti i pannelli laterali ed il pannello superiore. In certi modelli possono essere incorporati delle linguette di chiusura, delle maniglie, dei pannelli da espositori ecc.
- Cajas plegables y bandejas:** son en general de una única pieza de cartón ondulado. El fondo de la caja se pliega para formar dos, o todas las paredes laterales, y la tapa. Pueden incorporarse al diseño elementos de cierre, asas, paneles expositores, etc.

0400

M

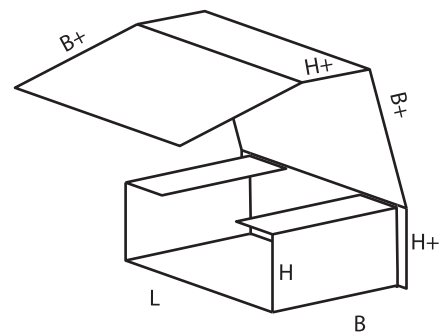
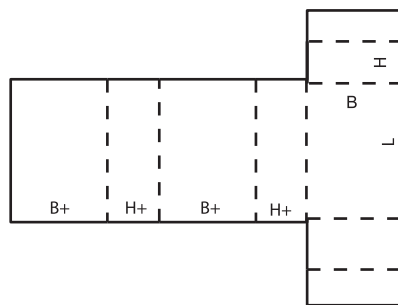

0401

M

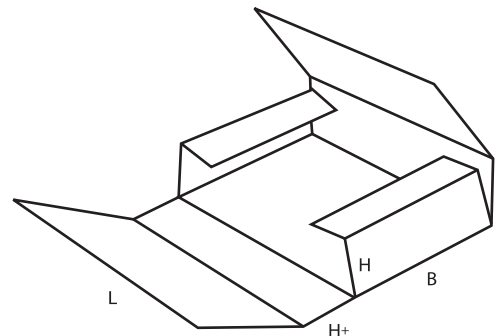
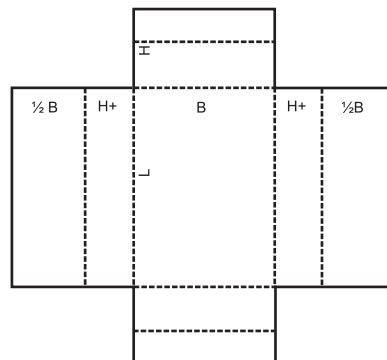

0402

M

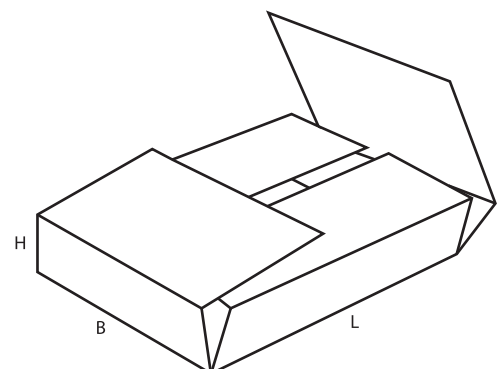
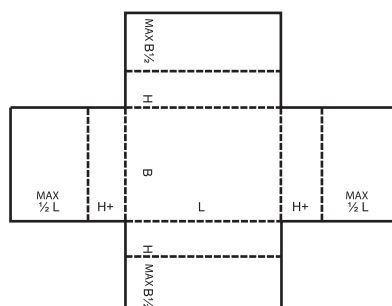

0403

M

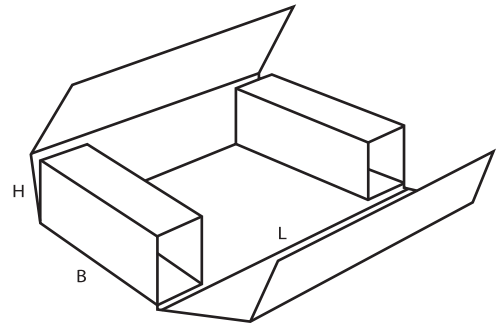
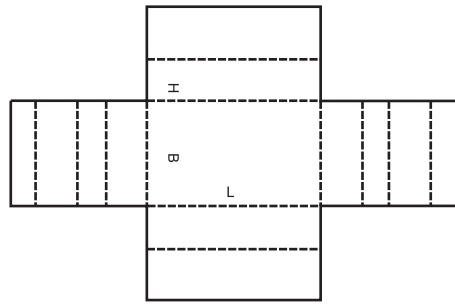

0404

M

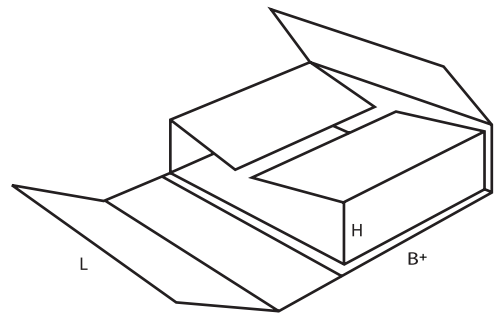
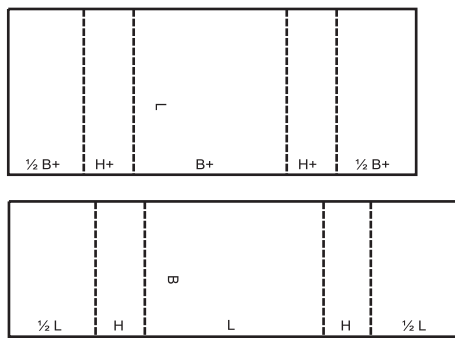

0405

M

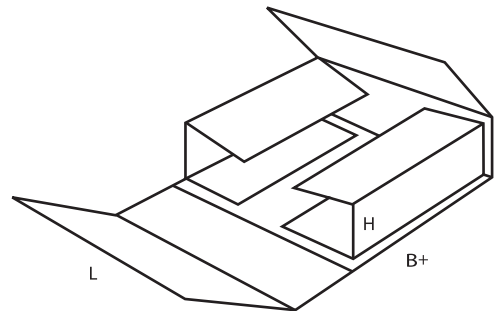
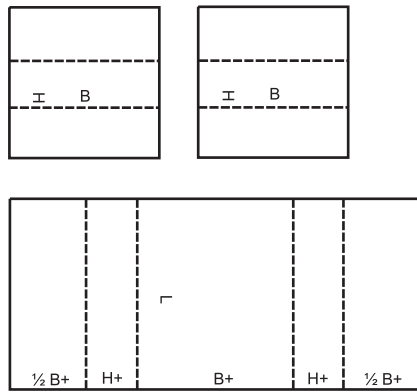

0406

A

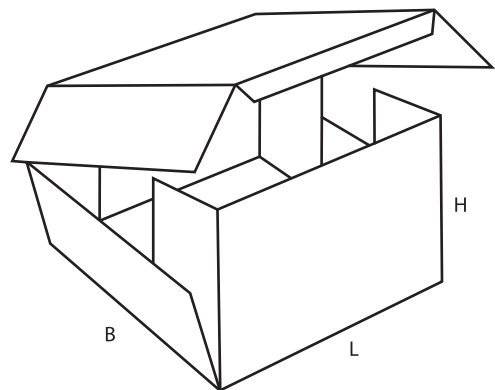
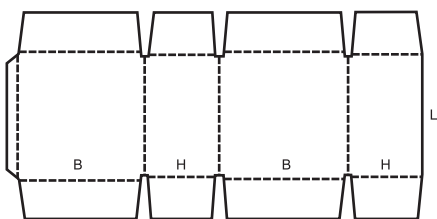

0409

M

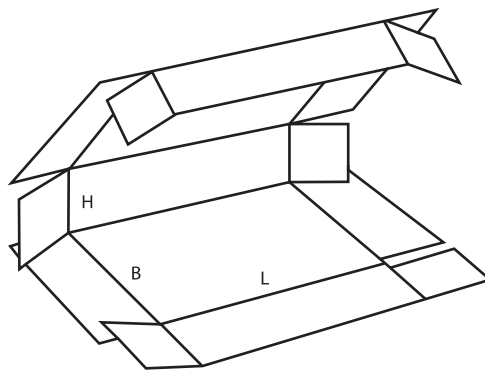
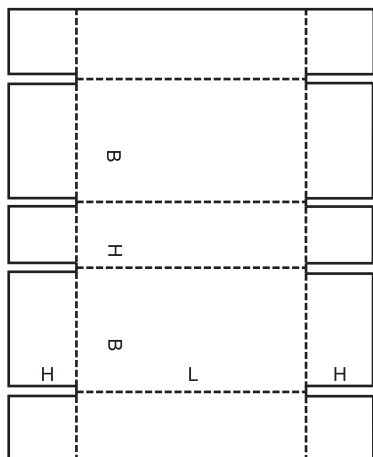

0410

M/A

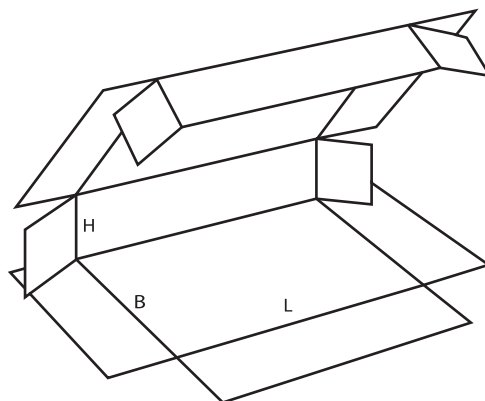
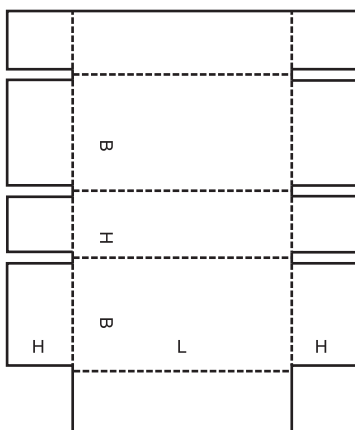

0411

M/A

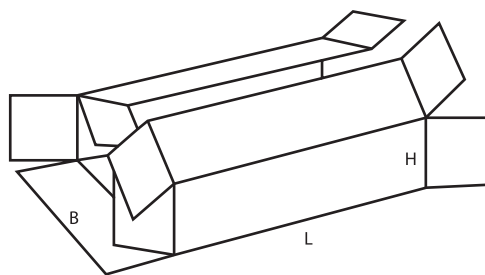
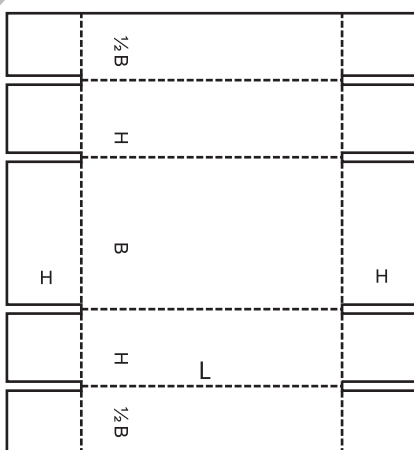

0412

M

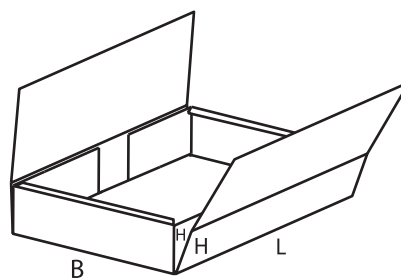
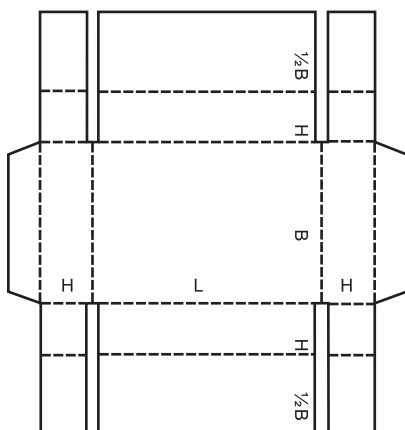

0413

M/A

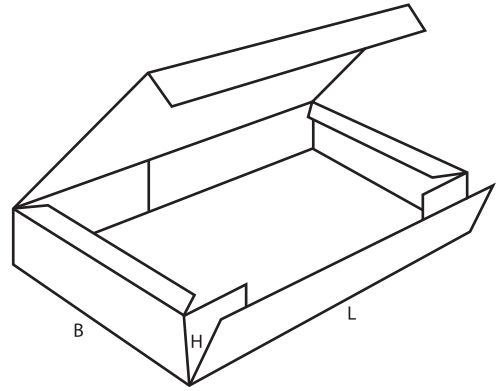
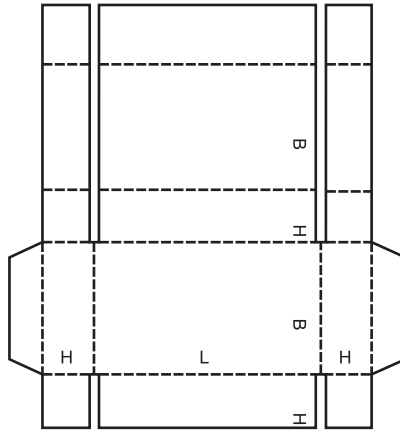

0415

M/A

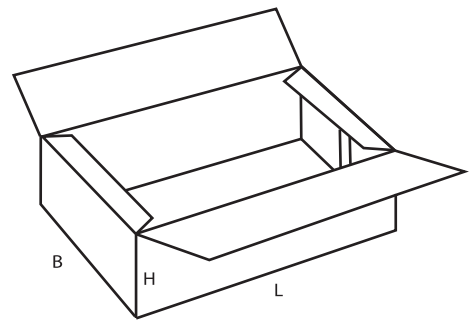
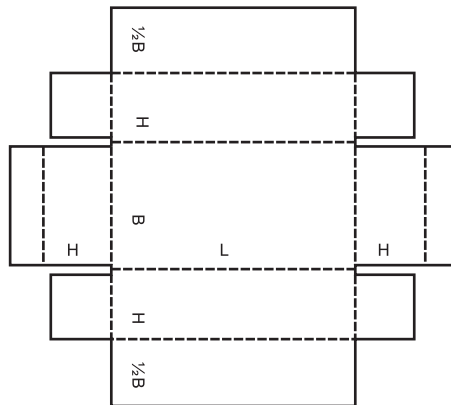

0416

M

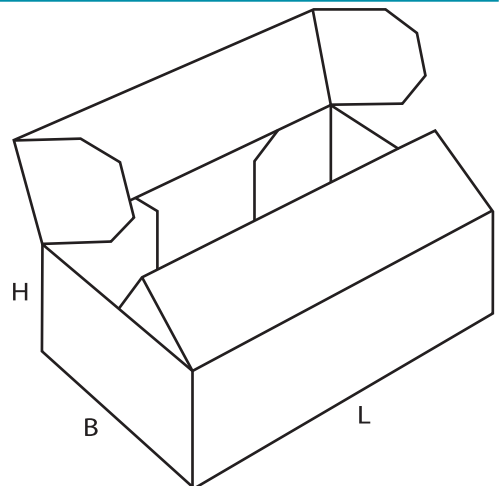
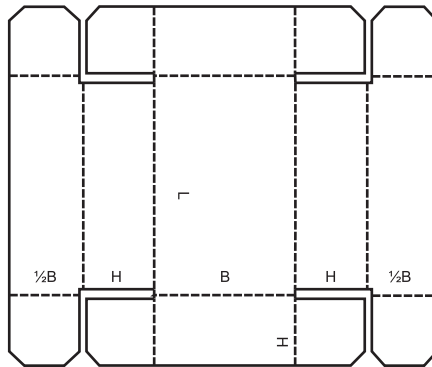

0420

M/A

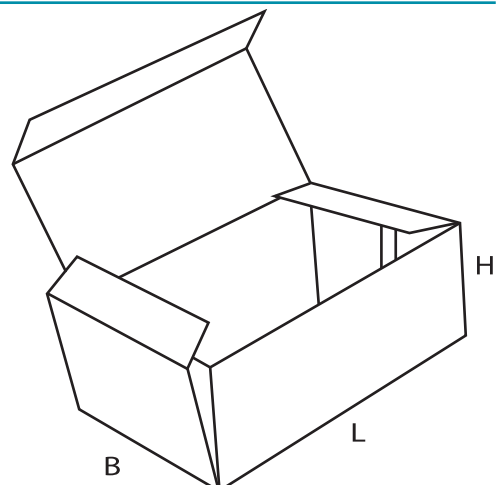
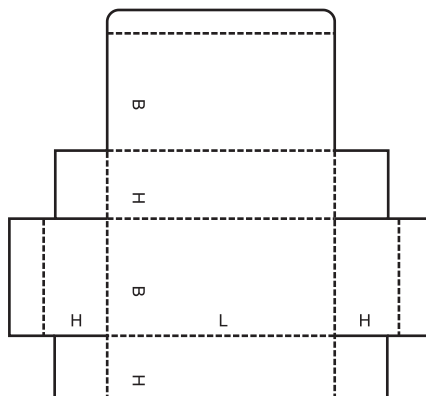

0421

M/A

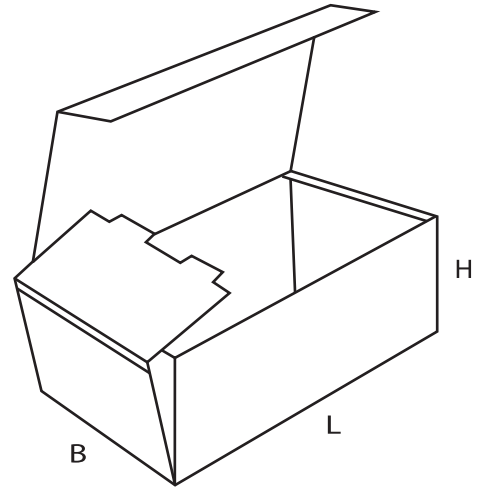
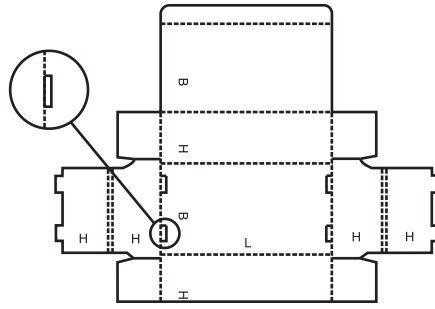

0422

M/A

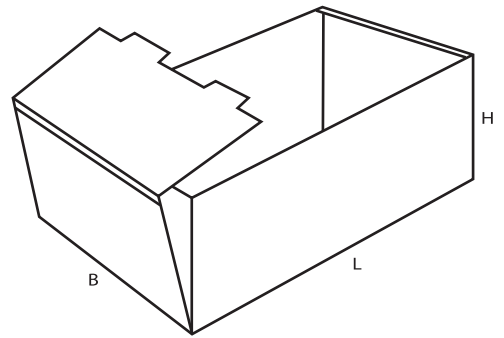
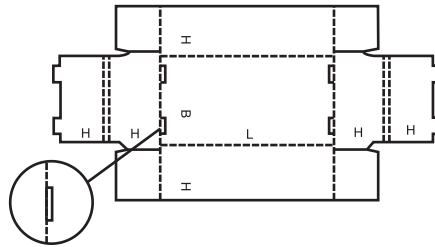

0423

M/A

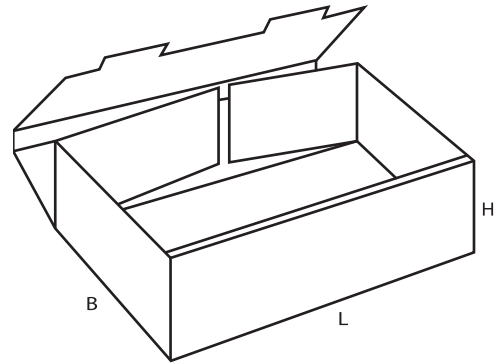
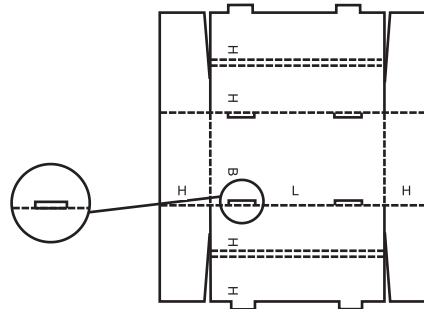

0424

M/A

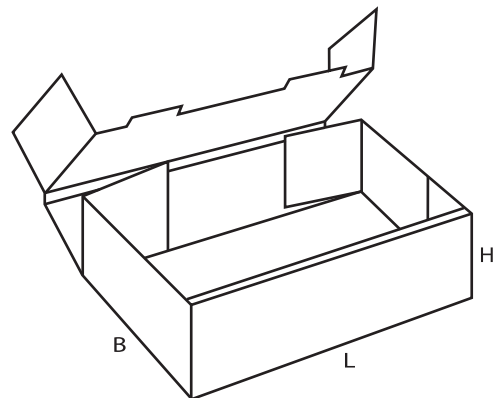
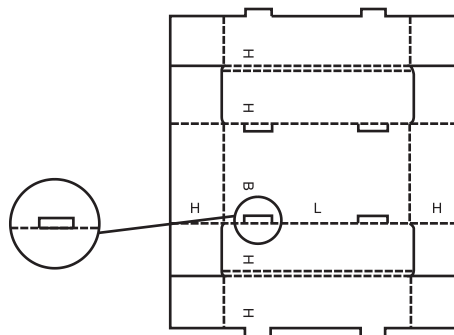

0425

M/A

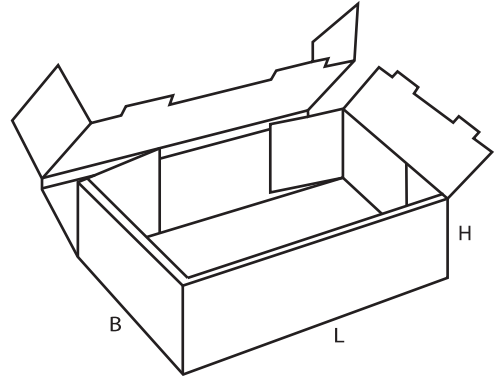
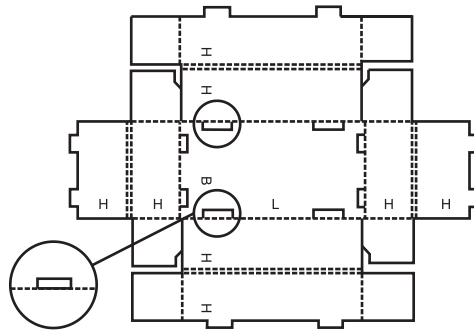

0426

M

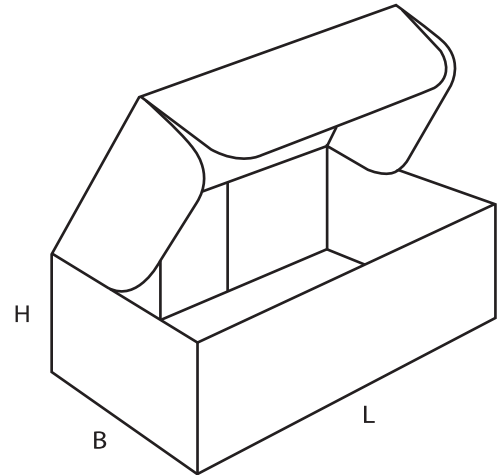
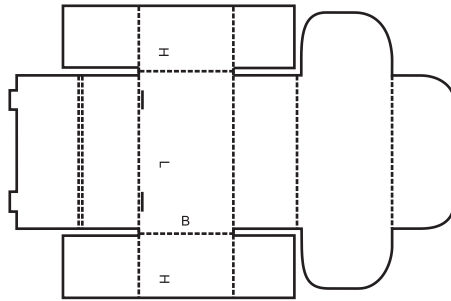

0427

M

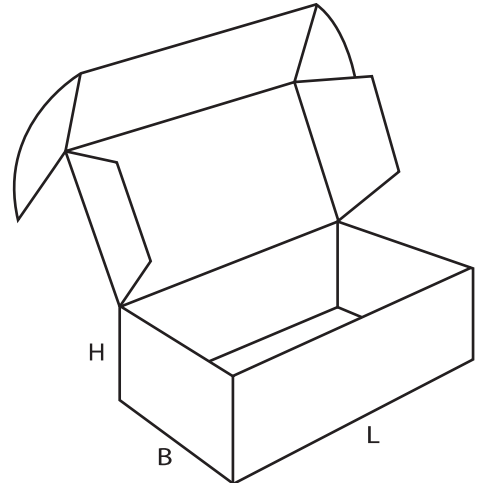
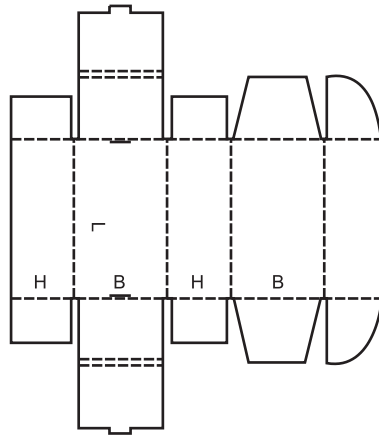

0428

M

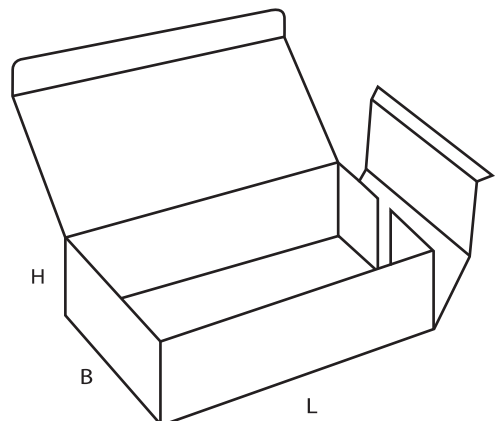
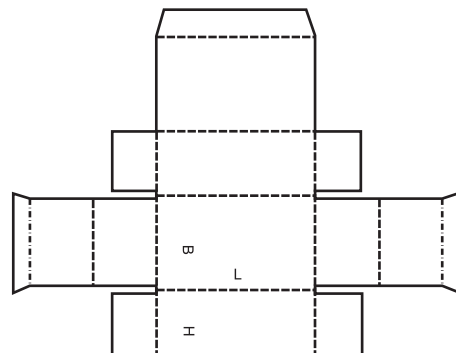

0429

M

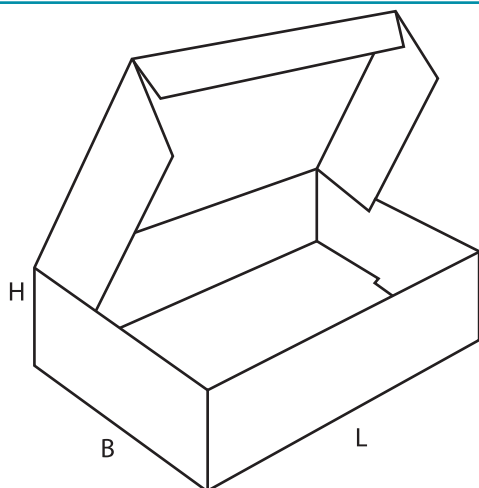
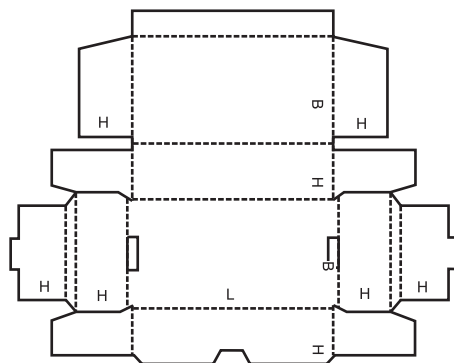

0430

M/A

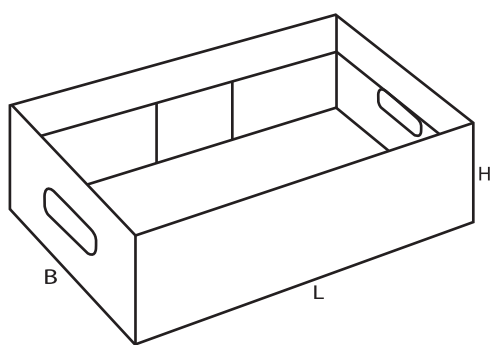
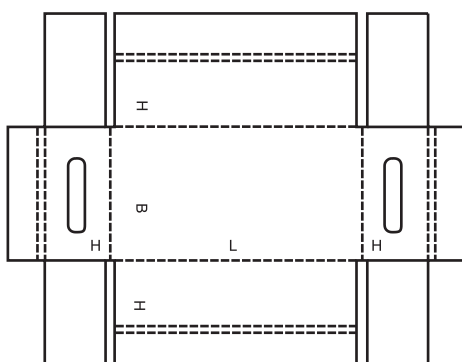

0431

M

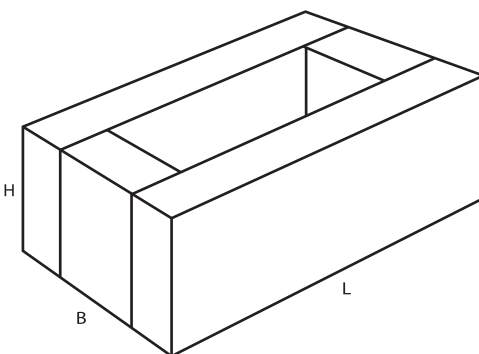
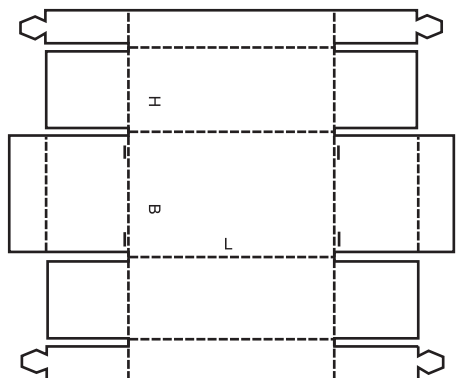

0432

M

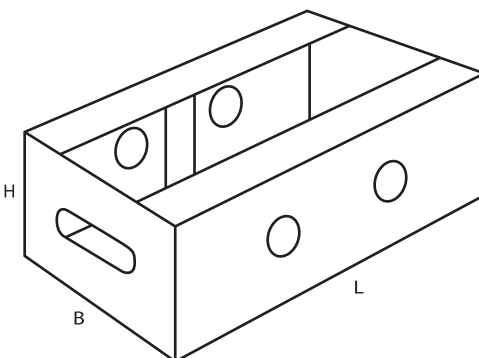
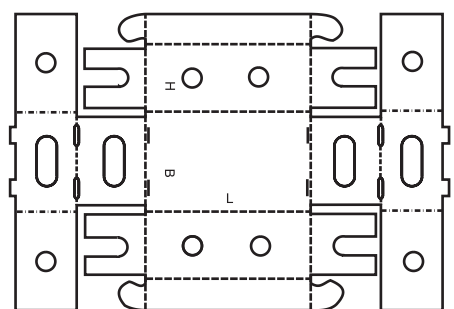

0433

M

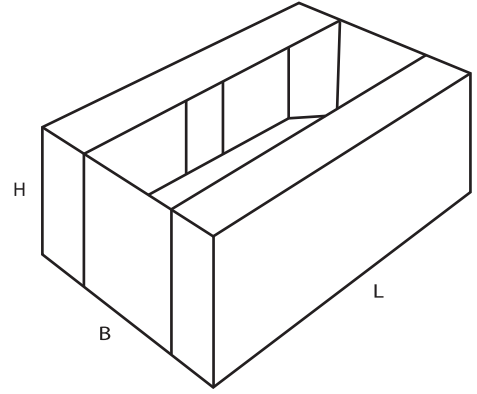
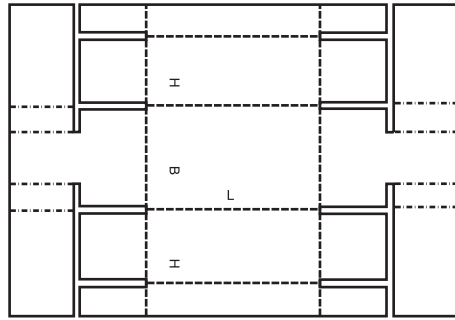

0434

M

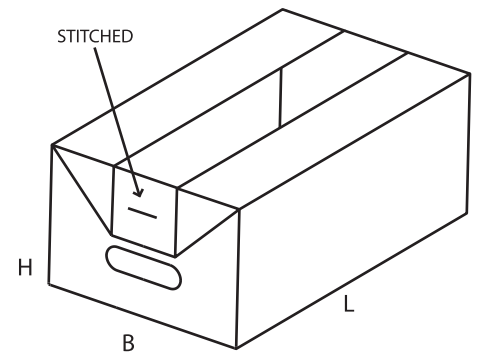
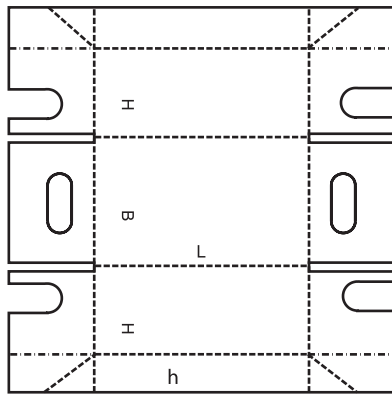

0435

M/A

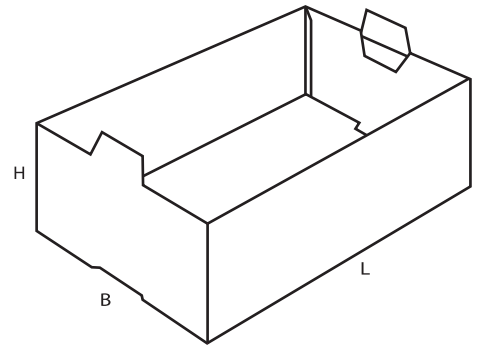
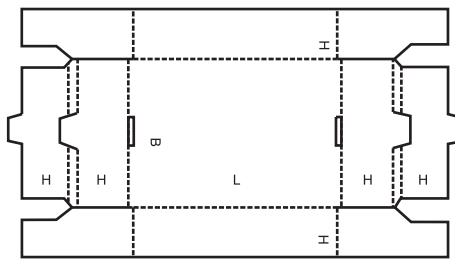

0436

M

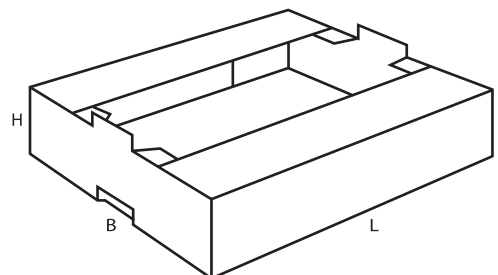
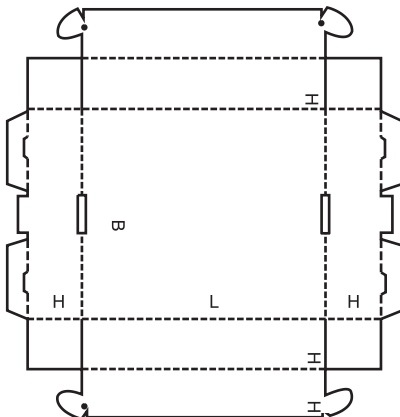

0437

M

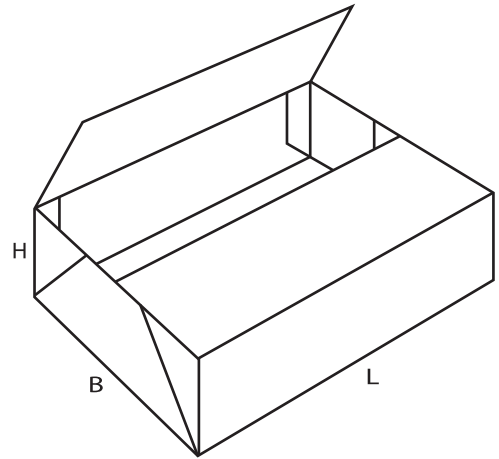
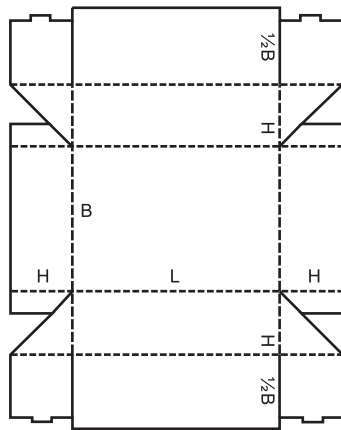

0440

A

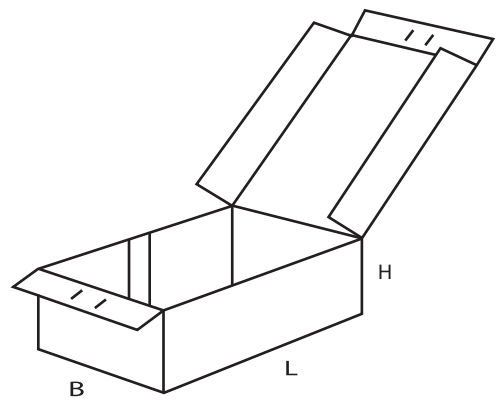
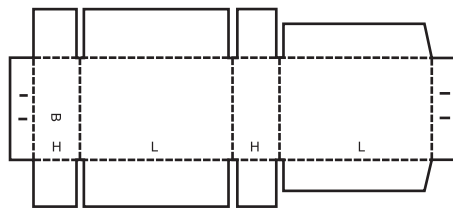

0441

A

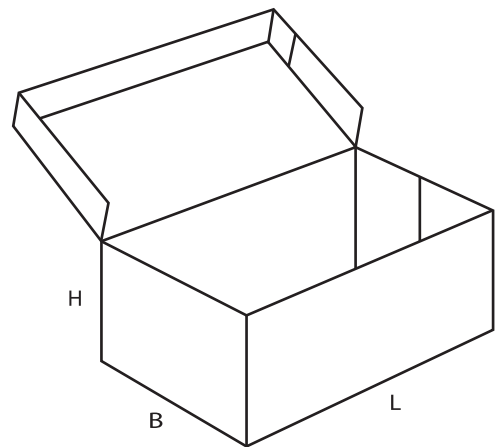
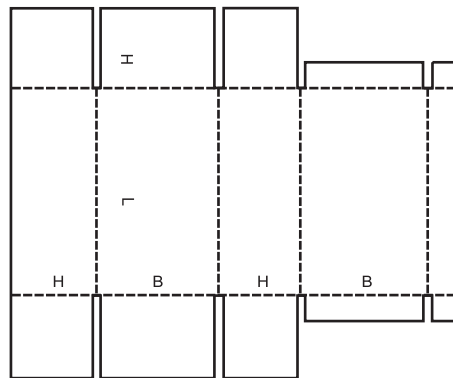

0442

M

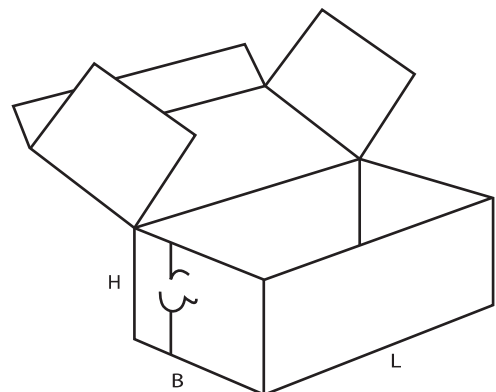
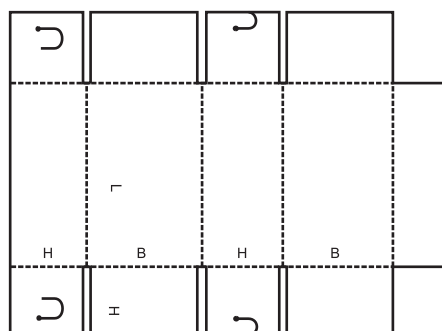

0443

M

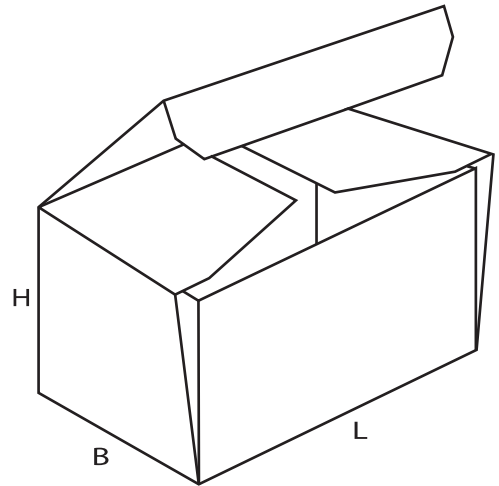
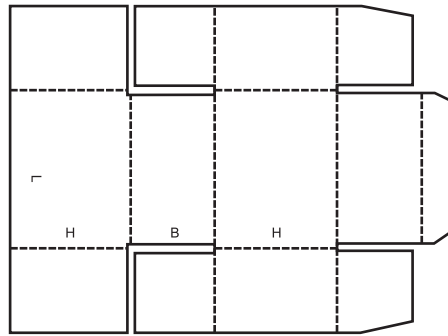

0444

M

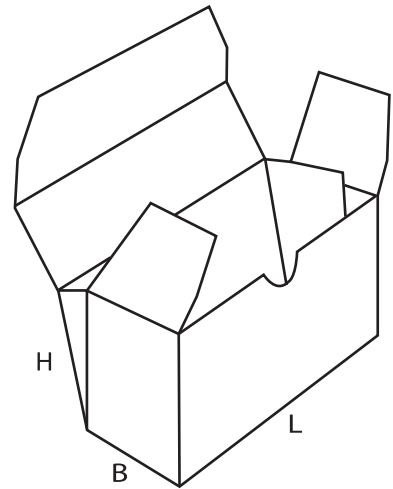
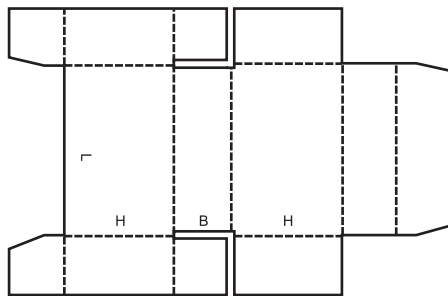

0445

M

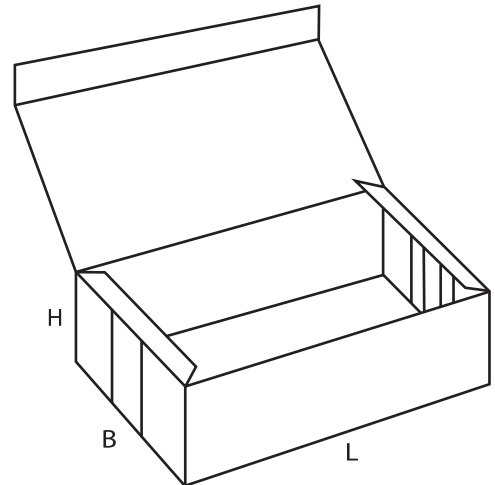
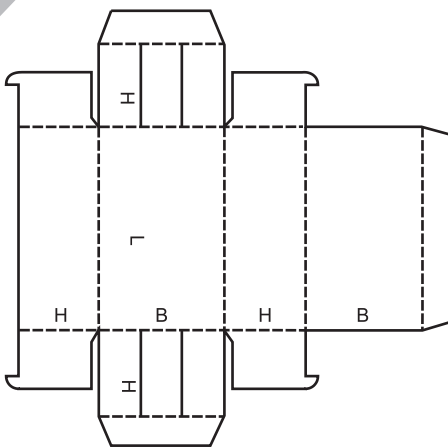

0446

A

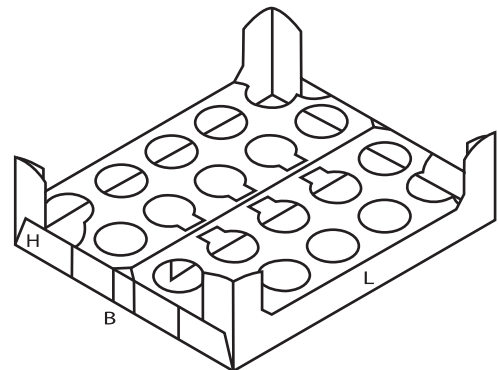
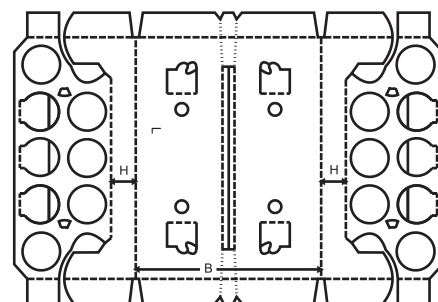

0447

M

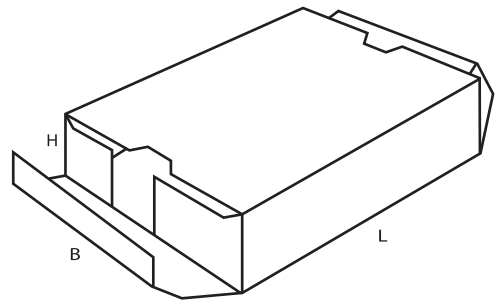
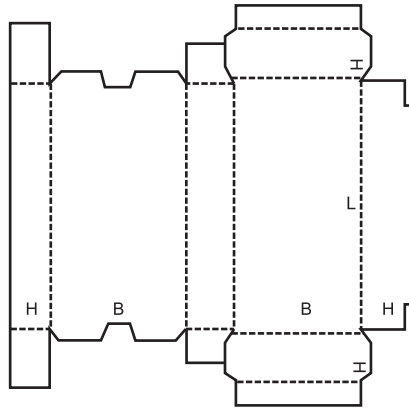

0448

M

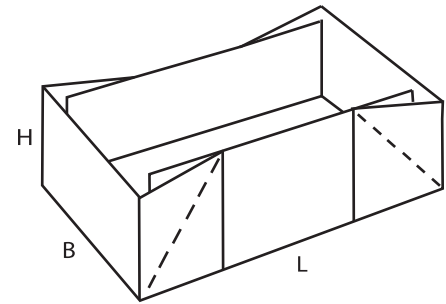
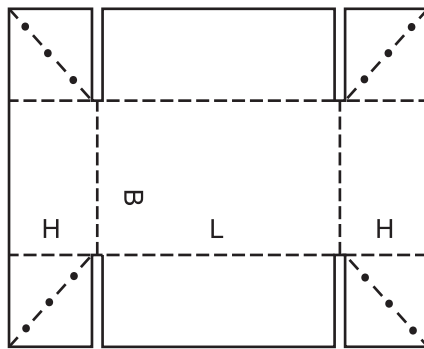

0449

M

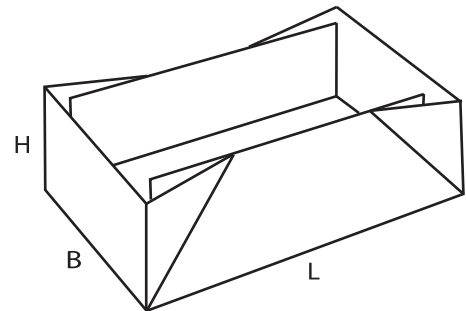
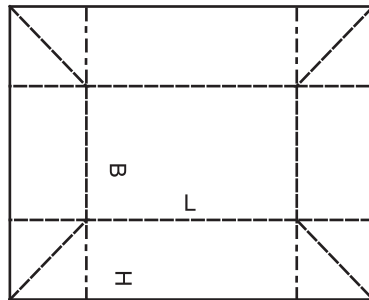

0450

M

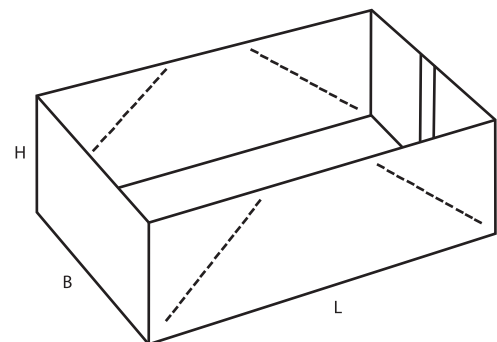
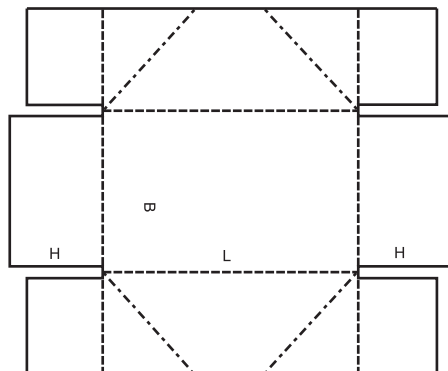

0451

M

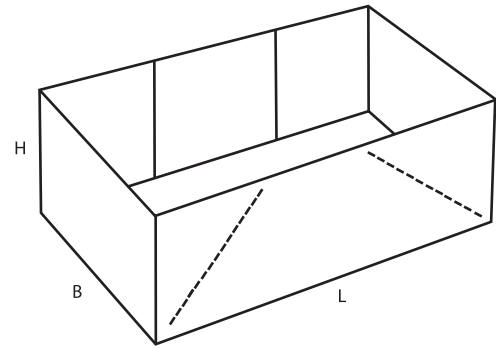
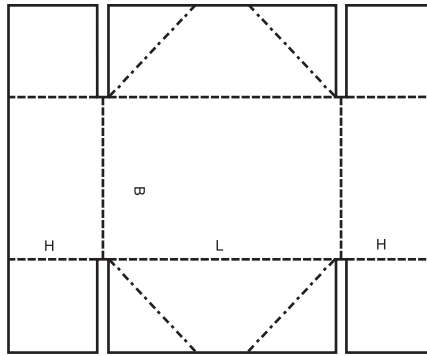

0452

A

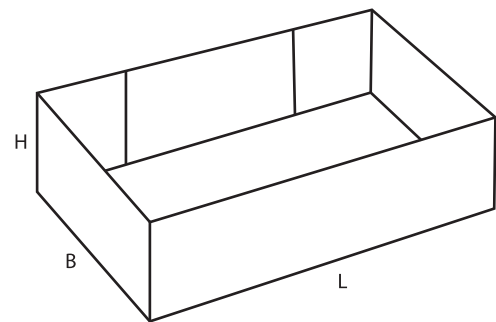
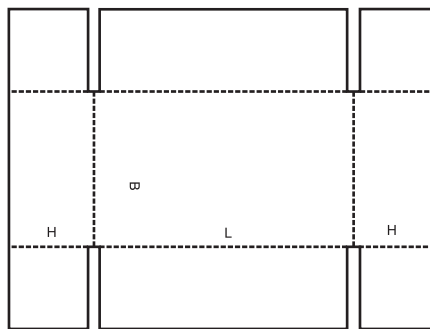

0453

A

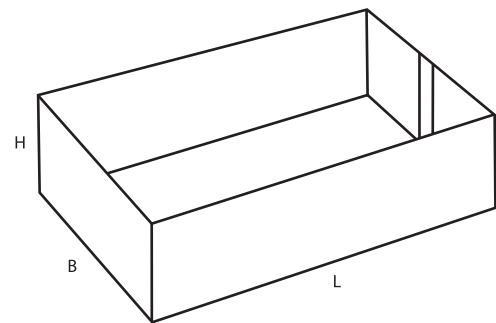
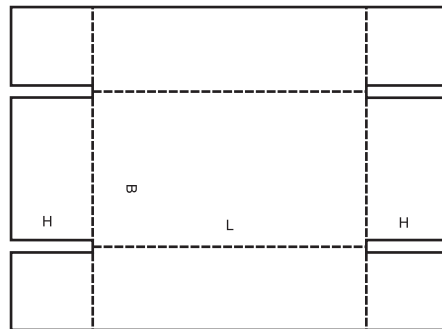

0454

M

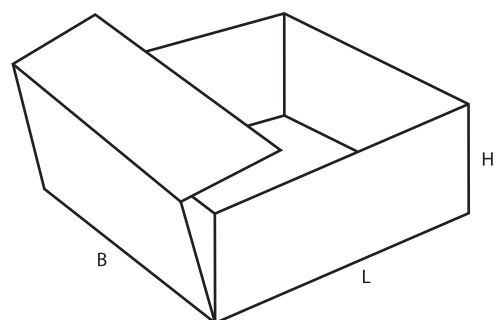
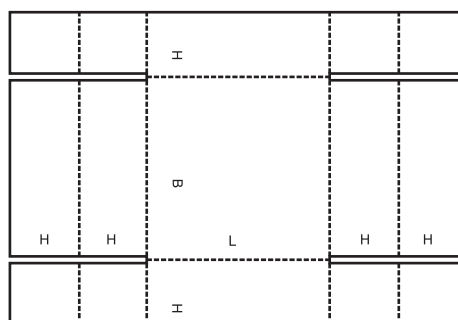

0455

M

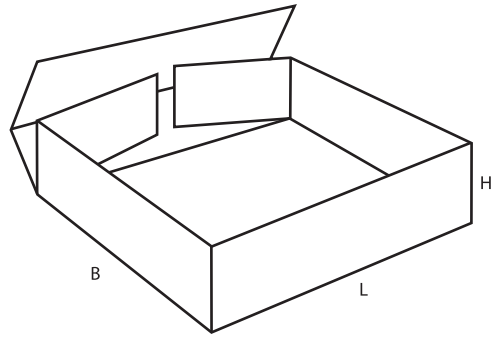
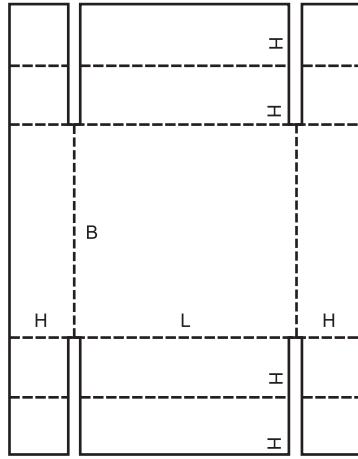

0456

M

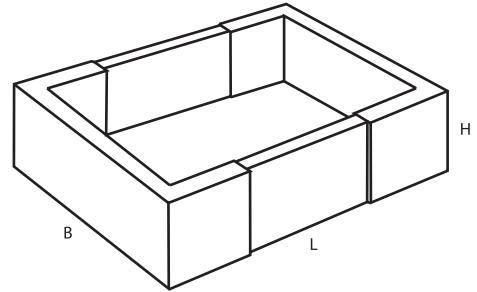
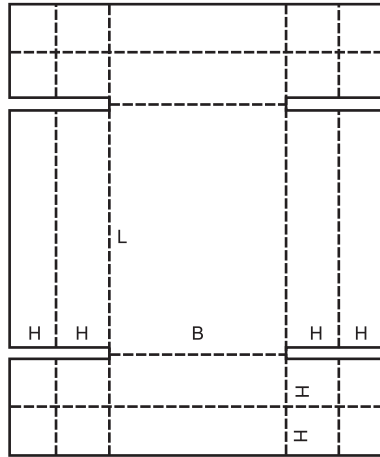

0457

M

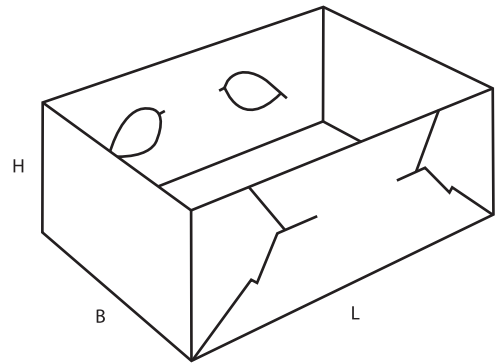
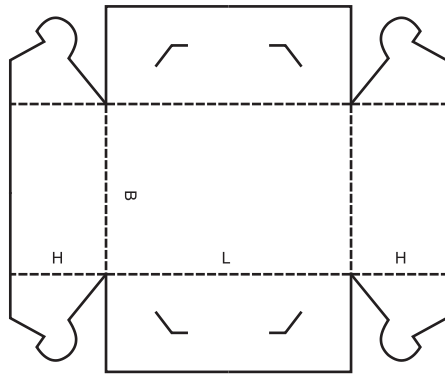

0458

M

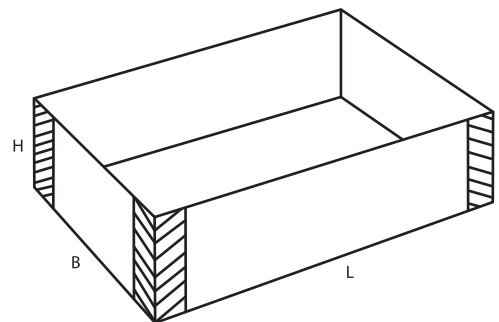
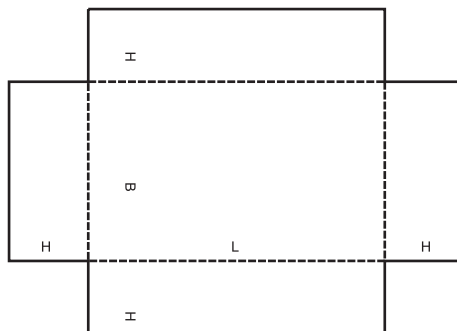

0459

A

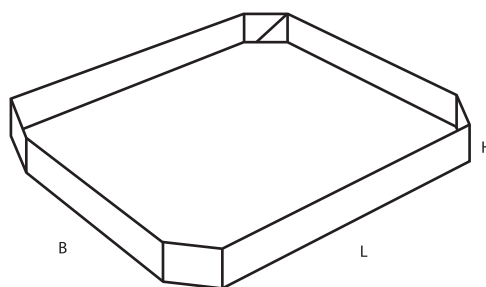
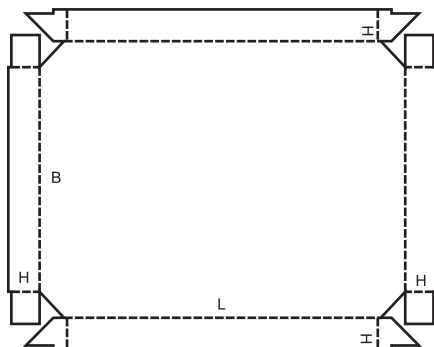

0460

A

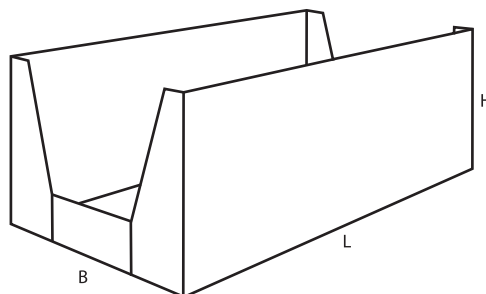
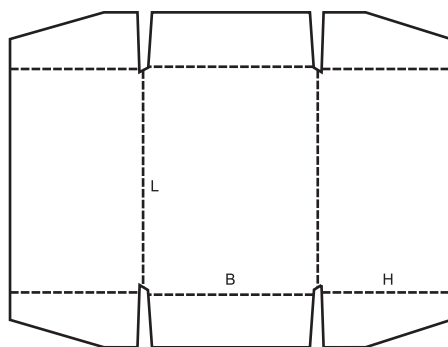

0470

M

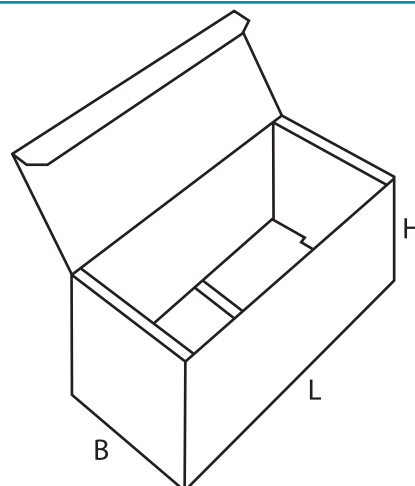
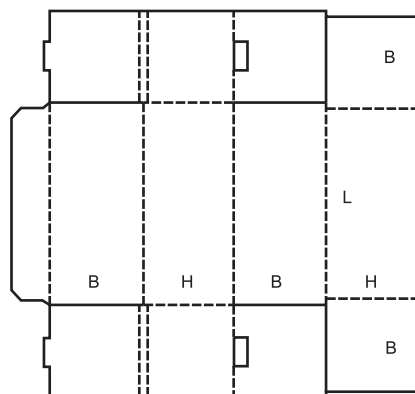

0471

M

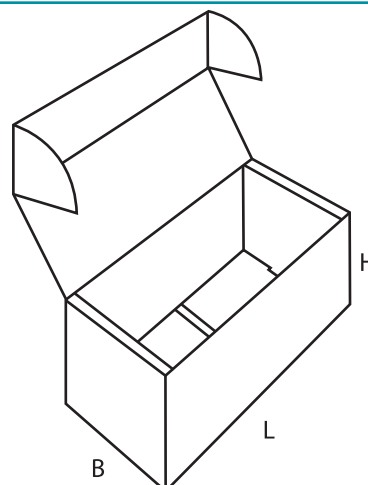
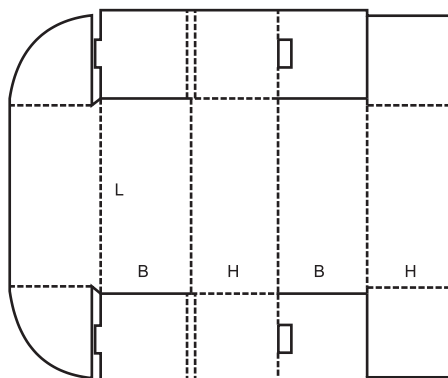

0472

M

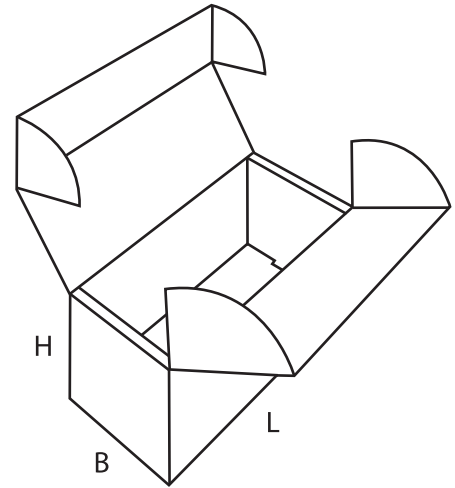
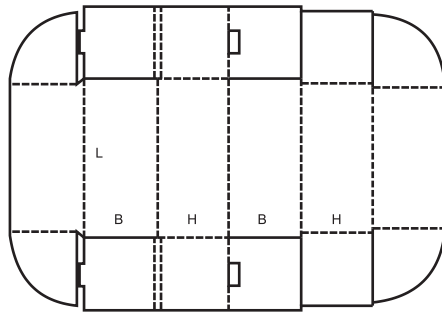

0473

M

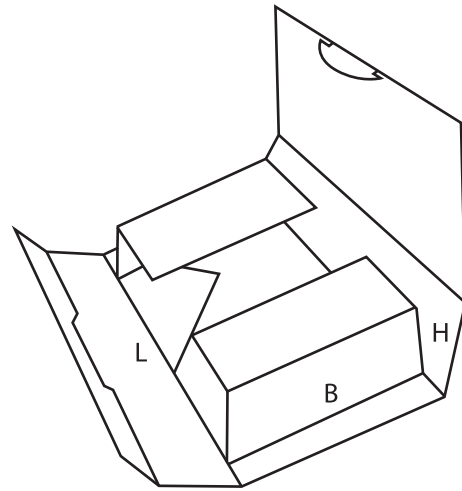
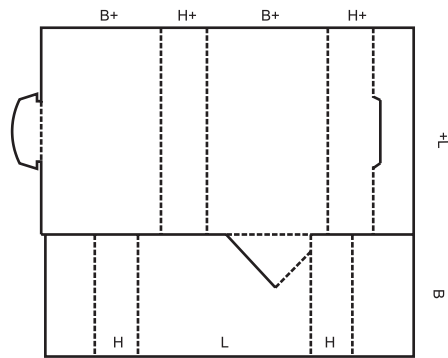

0500

▲ **Slide-type boxes** consist of several pieces of liners and sleeves sliding in different directions into each other. This group also includes outside sleeves for other cases.

▲ **Boîtes coulissantes** constituées par plusieurs manchons coulissants rentrant en différentes directions les uns dans les autres. Ce groupe comprend aussi les manchons extérieurs pour d'autres caisses.

▲ **Schiebeschachteln (Gürtelschachteln)** bestehen aus mehreren in verschiedenen Richtungen ineinanderschließbaren Ringeinsätzen und Manschetten. Zu dieser Gruppe gehören auch Überschiebhülsen.

▲ **Scatole scorrevoli:** Contenitori telescopico composti da diversi pezzi che scorrono l'uno con l'altro. In questo gruppo sono incluse anche le fasce esterne per scatole.

▲ **Cajas de tipo deslizante:** constan de varias piezas de forros interiores y fundas que deslizan en diferentes direcciones uno dentro de otro. Este grupo incluye también fundas exteriores para otras cajas.

0501

M

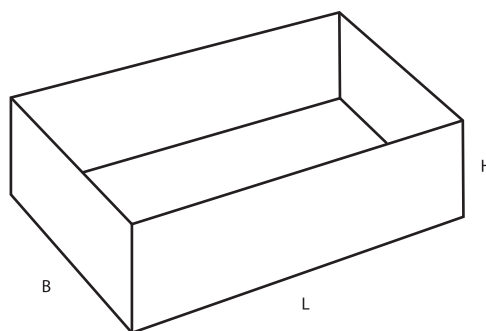
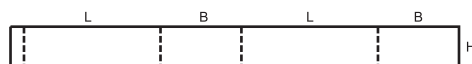

0502

M

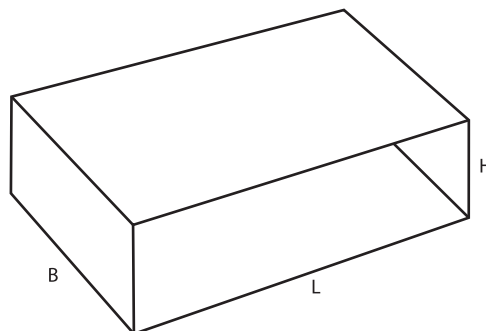
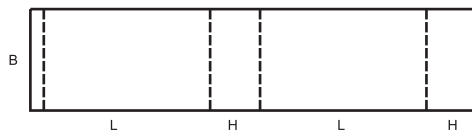

0503

M

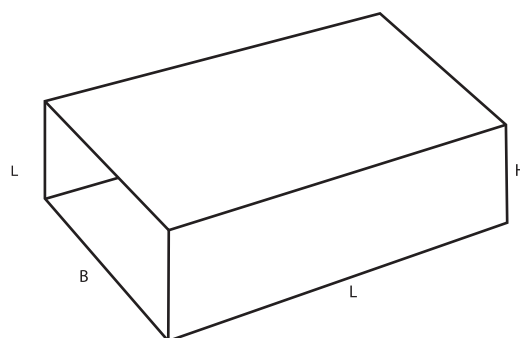
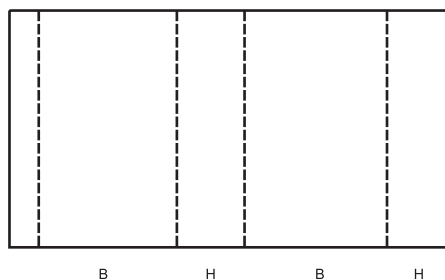

0504

M

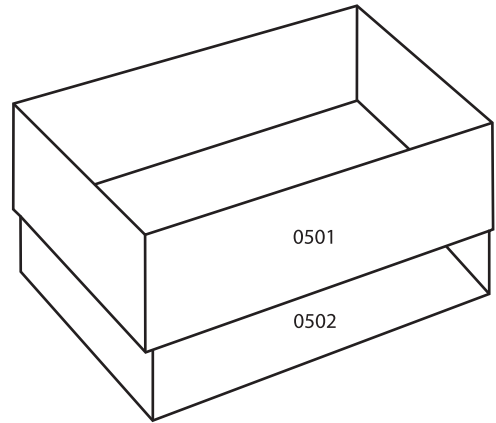
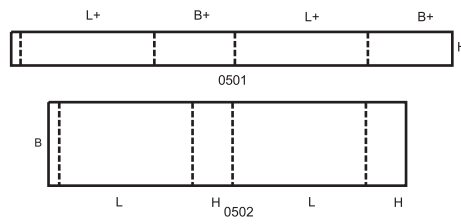

0505

M

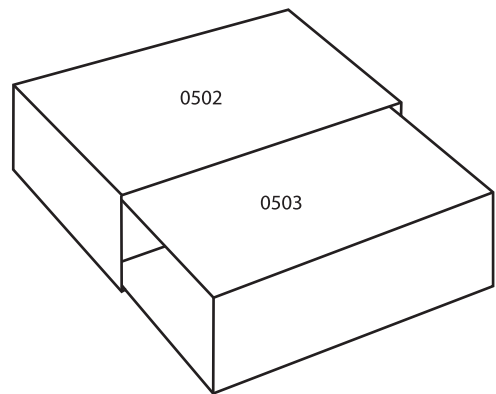
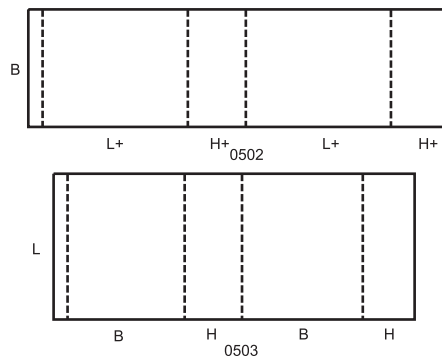

0507

M

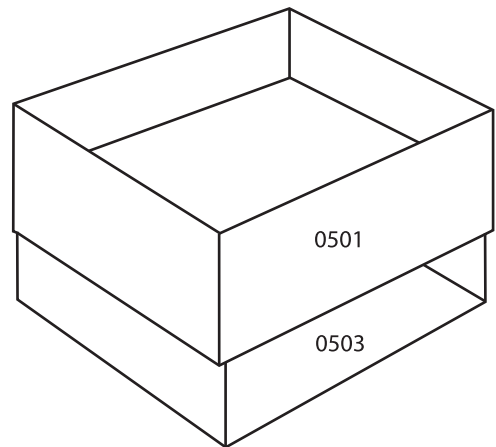
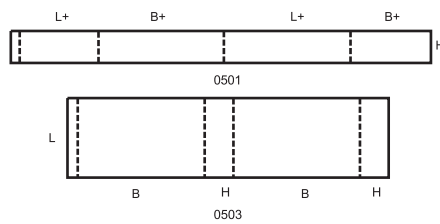

0509

M

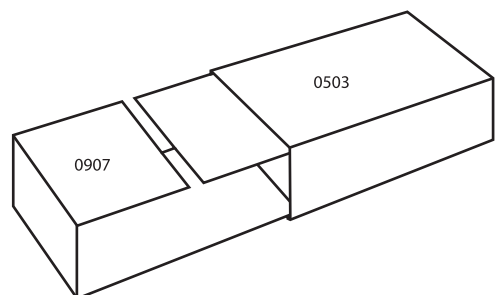
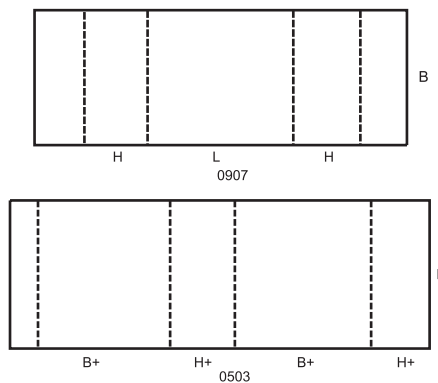

0510

M

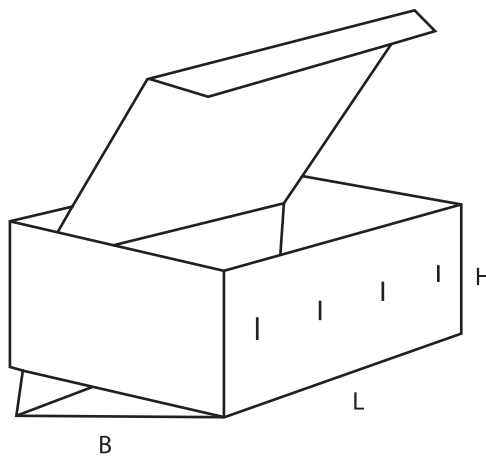
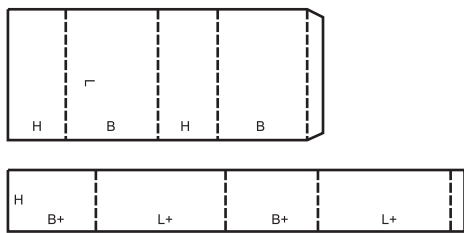

0511

M

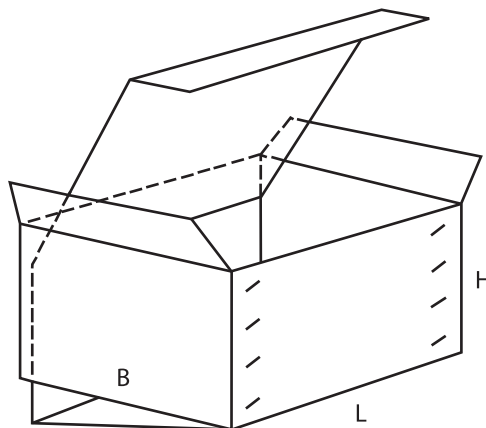
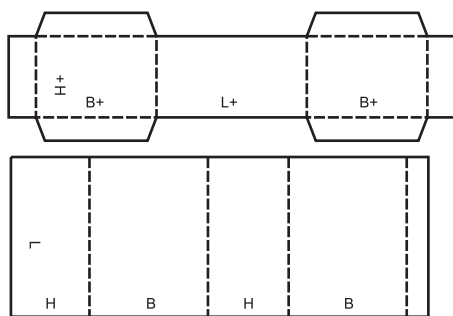

0512

M

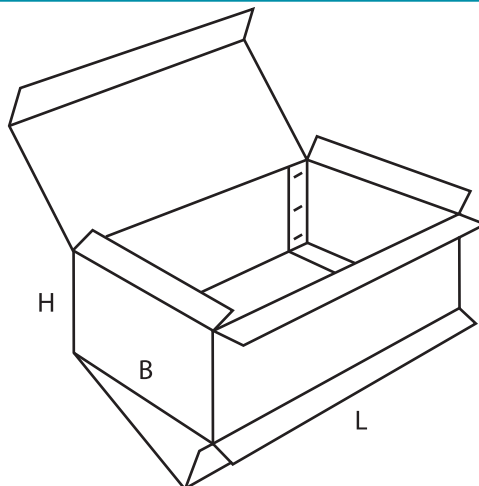
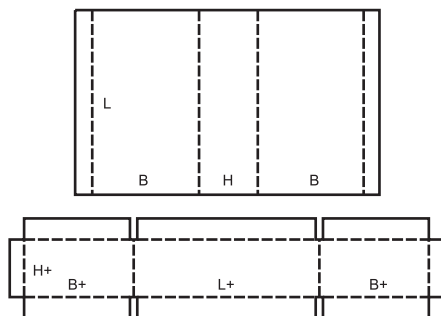

0600

- ▲ **Rigid-type boxes** consist of two separate end pieces and a body and require stitching or a similar operation before they can be used.
- ▲ **Caisses rigides** constituées de plusieurs pièces nécessitant un assemblage avant emploi.
- ▲ **Formfeste Schachteln** bestehen in der Regel aus zwei Seitenteilen und einem Mittelteil, das Boden und Dekkel bildet. Diese Schachteln können als vorbereitete Zuschnitte geliefert werden und sind dann vom Verbraucher durch Drahtheftung zu verbinden.

- ▲ **Casse rigide:** Imballaggi rigidi composti da due pezzi laterali separati e un corpo, e richiedono una fase di cucitura o altro prima di essere utilizzati.
- ▲ **Cajas de tipo rígidas:** formadas por dos piezas separadas, para los extremos y un cuerpo; requieren un grapado u otra operación similar antes de que puedan utilizarse.

0601

A

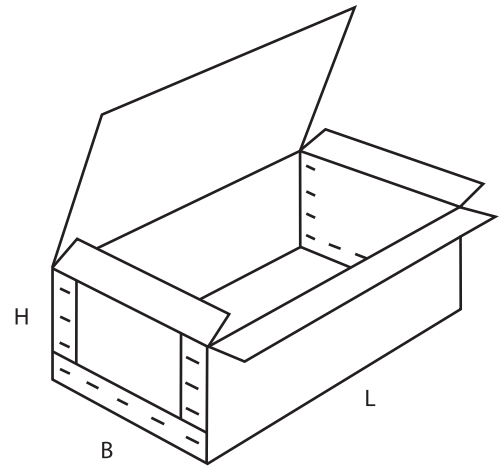
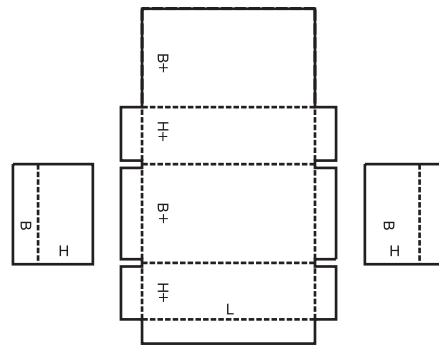

0602

A

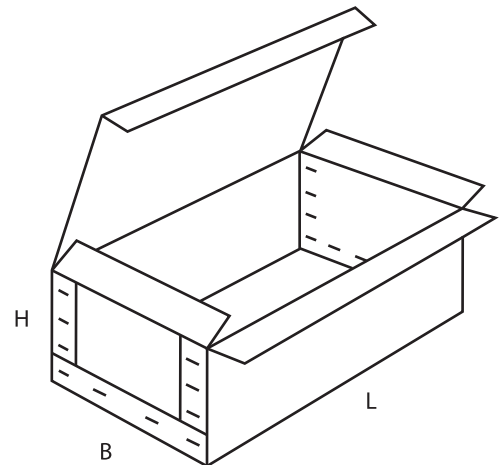
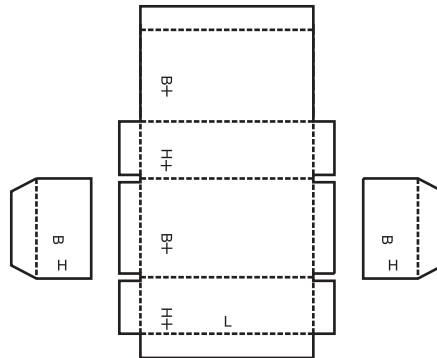

0605

A

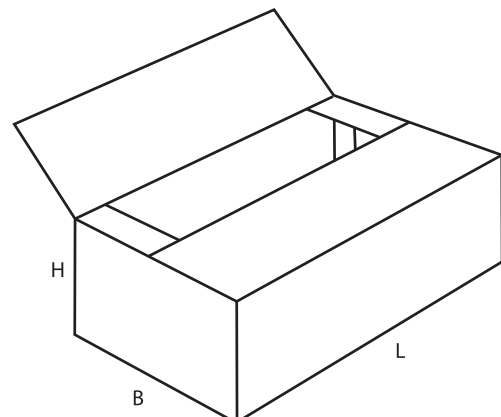
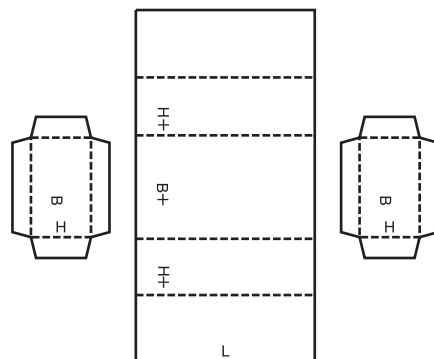

0606

A

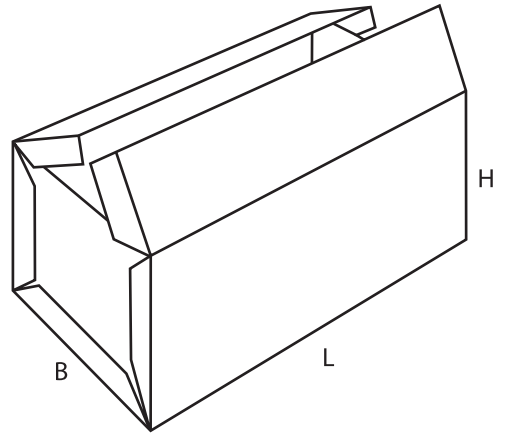
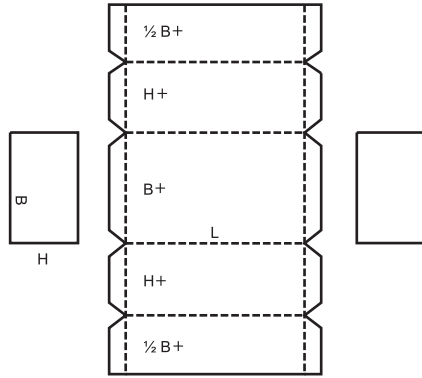

0607

A

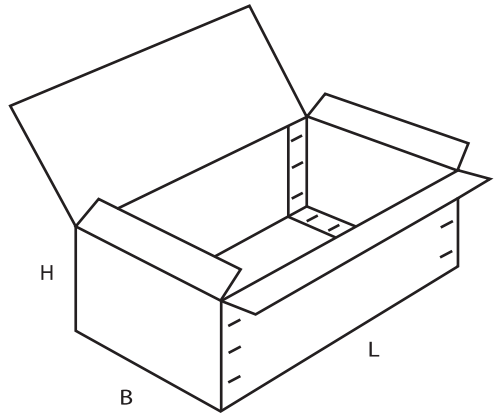
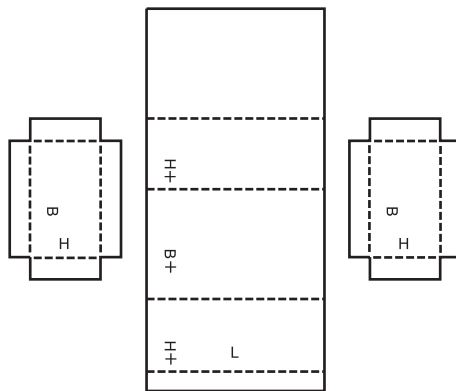

0608

A

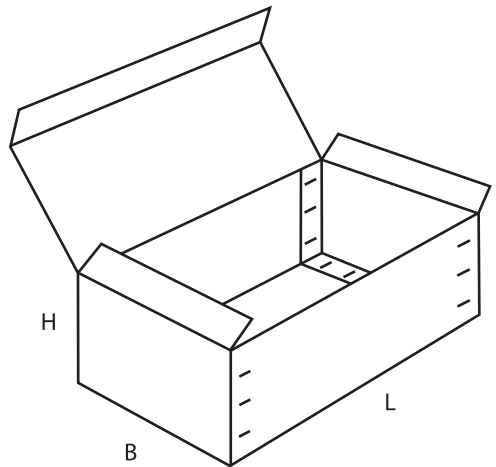
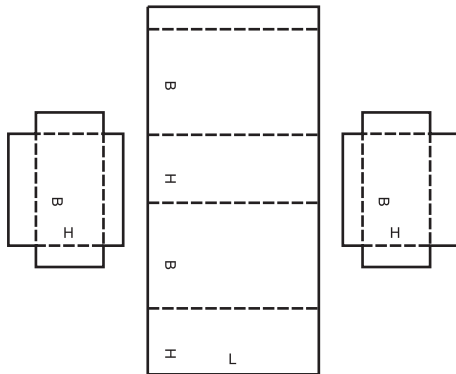

0610

M/A

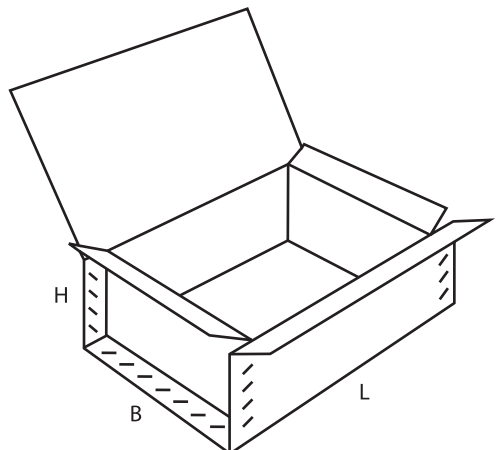
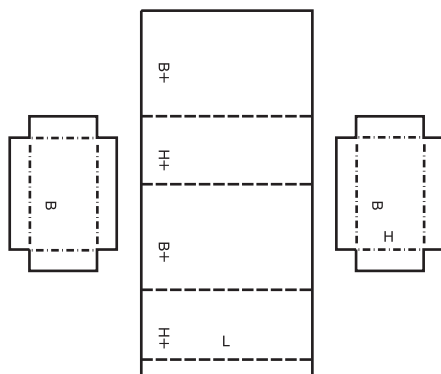

0615

M/A

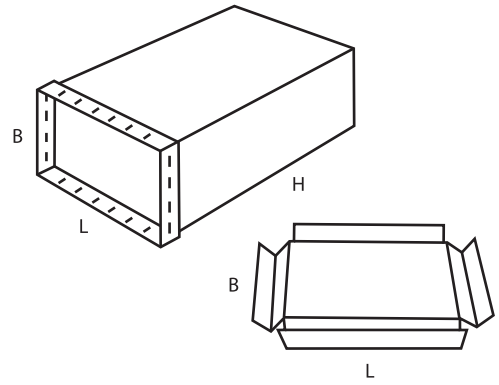
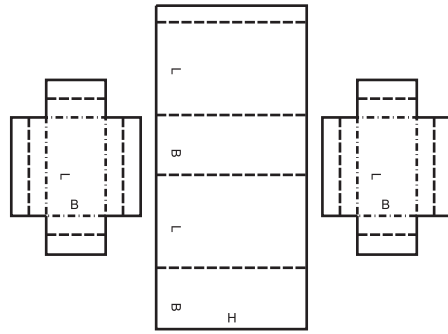

0616

M/A

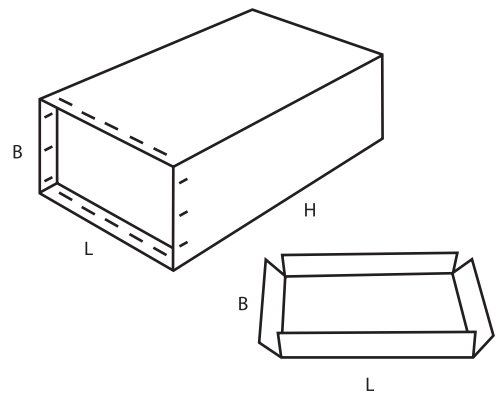
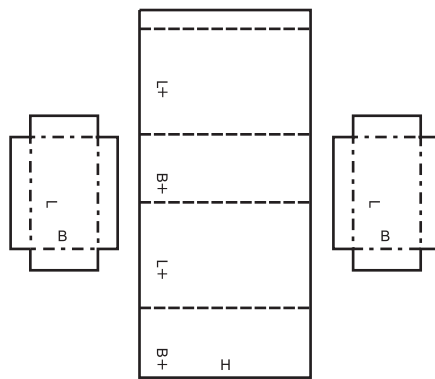

0620

A

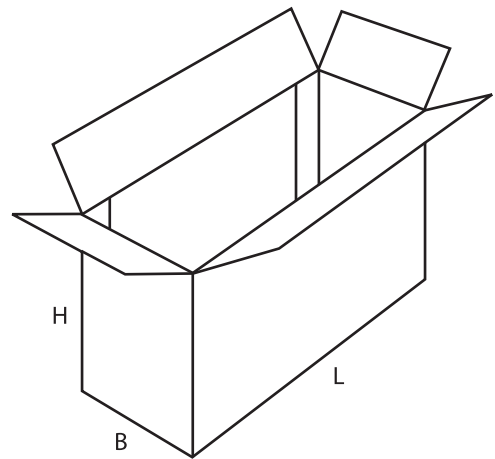
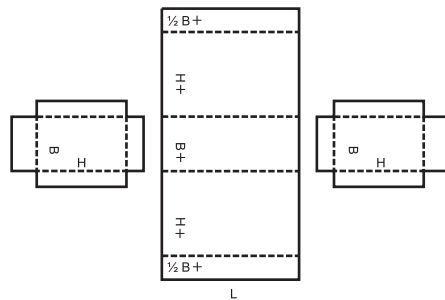

0621

M

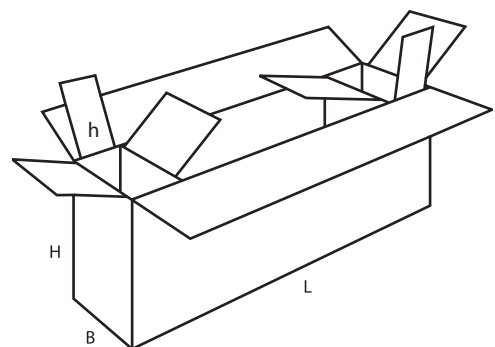
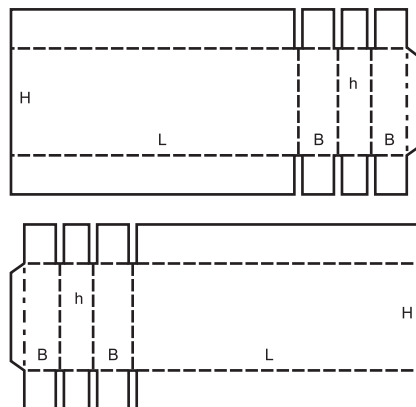

0700

- ▲ **Ready-glued** cases consist of basically one piece, are shipped flat and ready to use by simple setting up.
- ▲ **Caisses collées** prêtes à l'emploi, constituées en principe par une seule pièce, livrées à plat et prêtes à l'emploi après un simple montage.
- ▲ **Fertig geklebte** Schachteln sind einteilige, faltbare Schachteln, die zusammengelegt geliefert und durch einfaches Aufrichten gebrauchsfertig aufgestellt werden. Die Schachteln können mit einem Faldboden (Faldbodenschachtel) oder mit Diagonalbiegung (Aufrichteschachtel) ausgerüstet sein.

- ▲ **Casse incollate e pronte all'uso:** Imballaggi incollati già pronti composti in genere da un pezzo, sono consegnati piegati e sono pronti per l'uso tramite una semplice fase di montaggio apertura.
- ▲ **Cajas de encolado rápido:** están hechas generalmente de una sola pieza, se entregan extendidas en un plano o plegadas y listas para su utilización por medio de un sencillo montaje.

0700

M

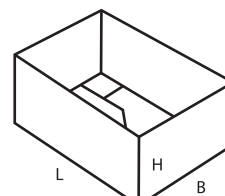
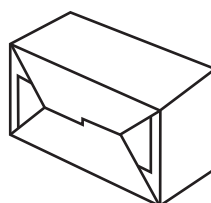
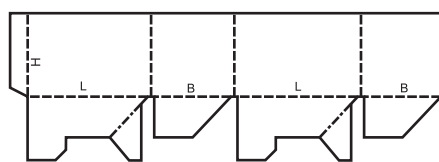

0701

M

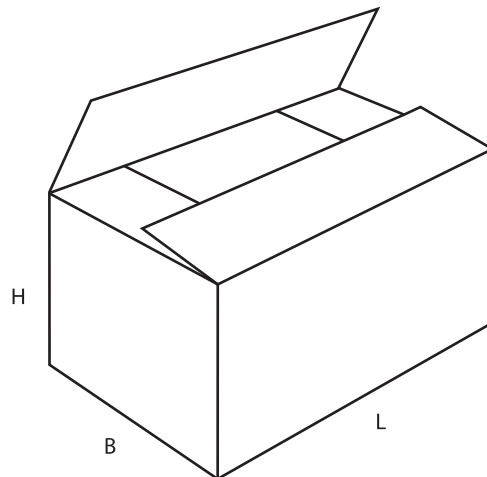
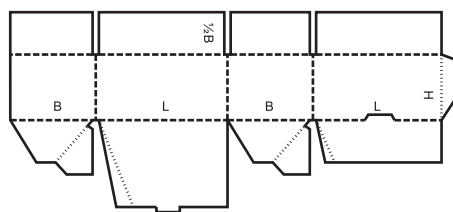

0703

M

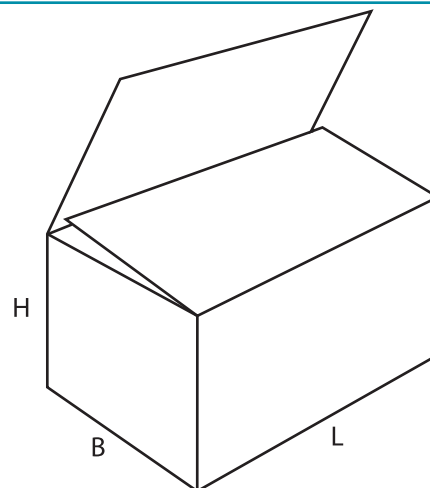
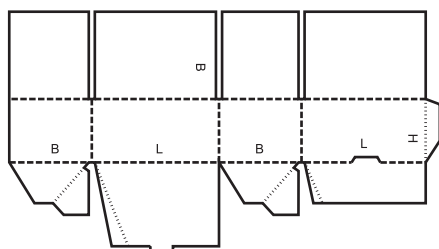

0711

M

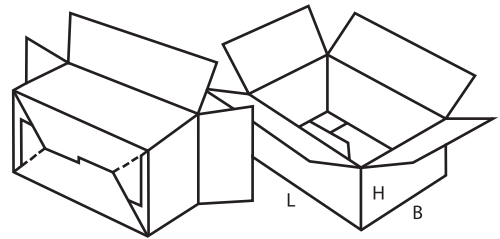
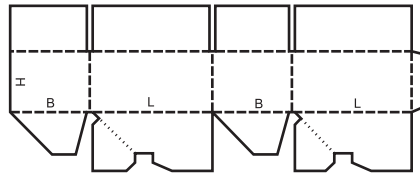

0712

M

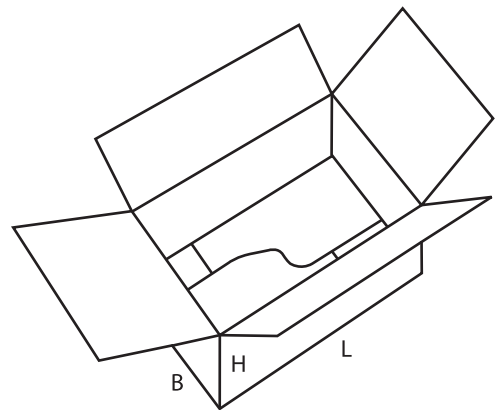
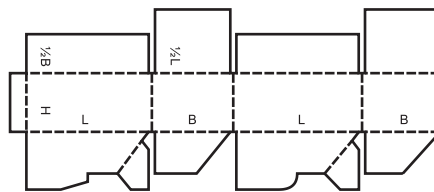

0713

M

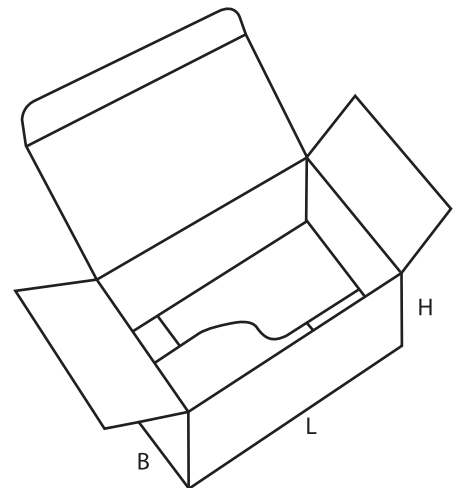
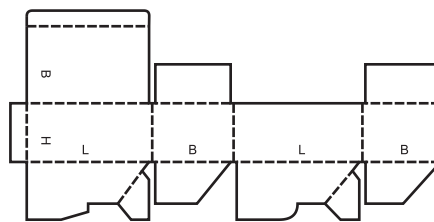

0714

M

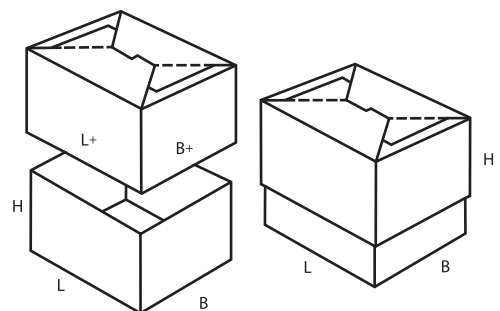
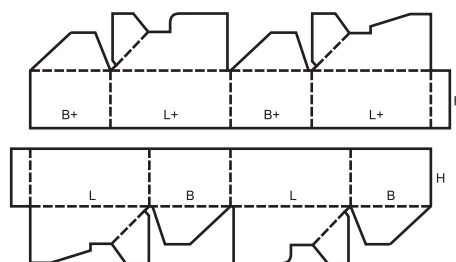

0715

M

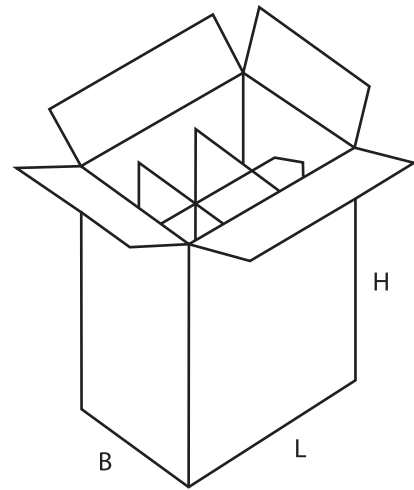
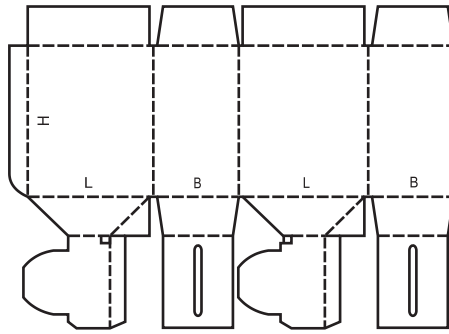

0716

M

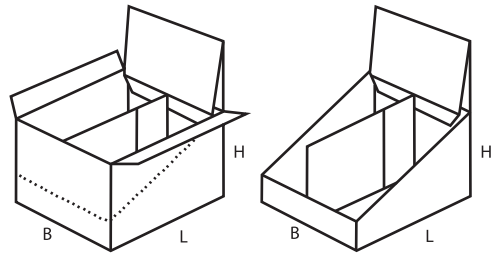
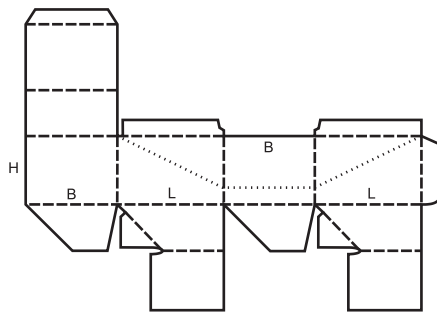

0717

M

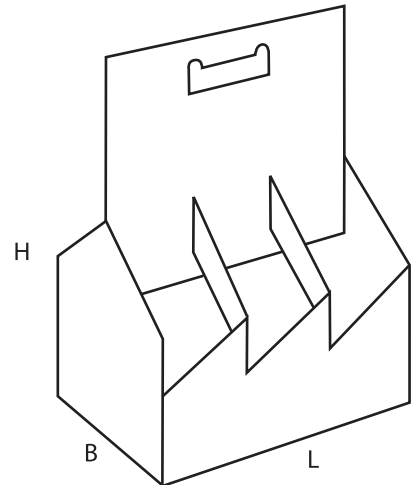
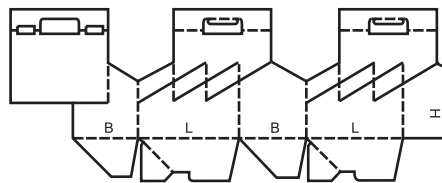

0718

M

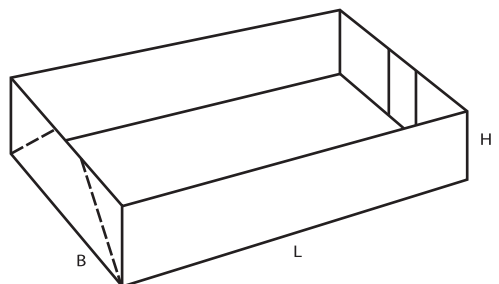
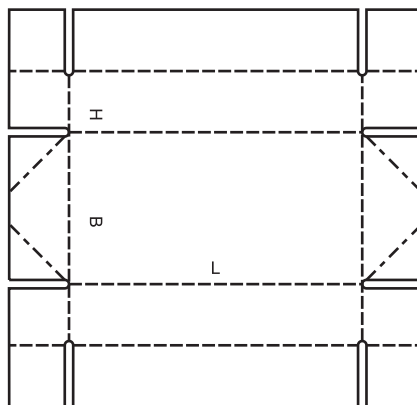

$B \geq 2H$

0747

M

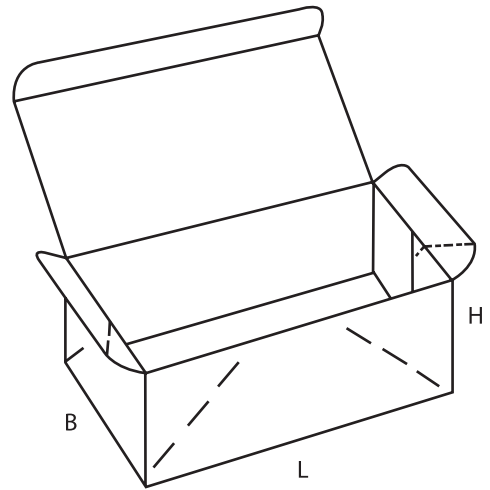
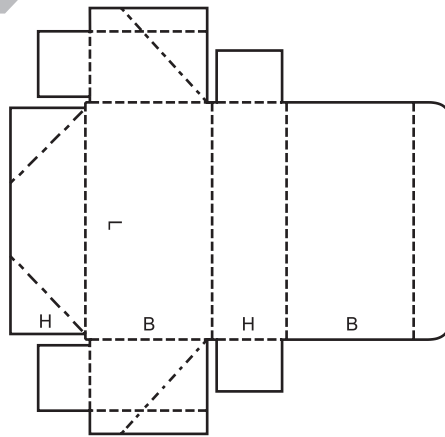

0748

M

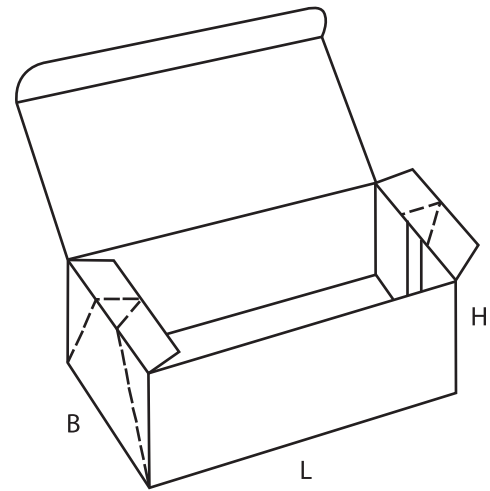
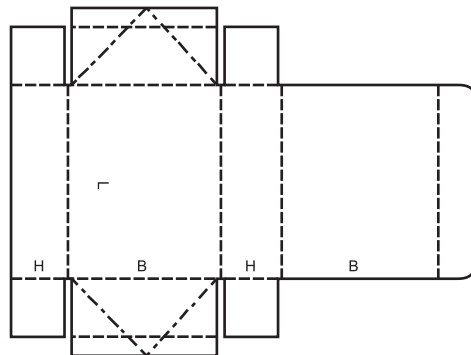

0751

M

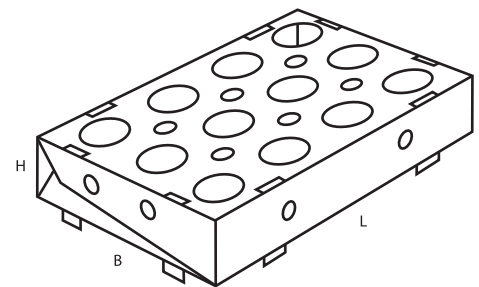
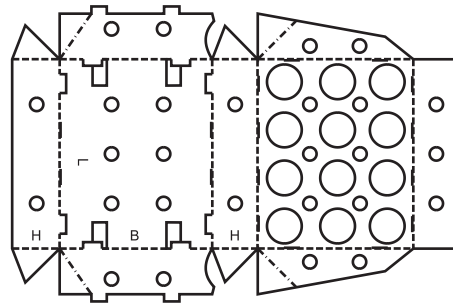

0752

M/A

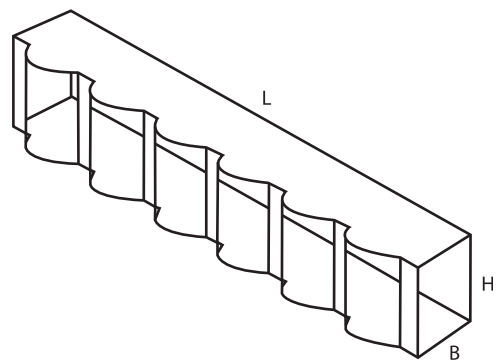
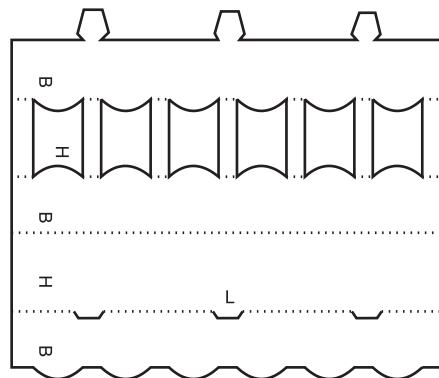

0759

M

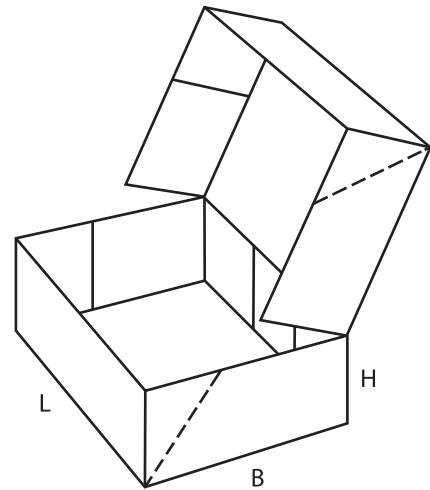
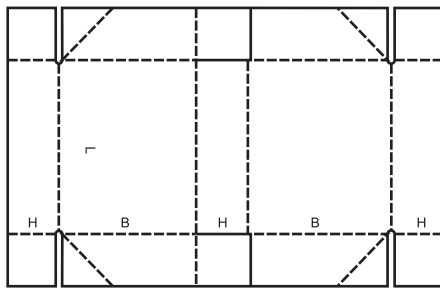

0761

M

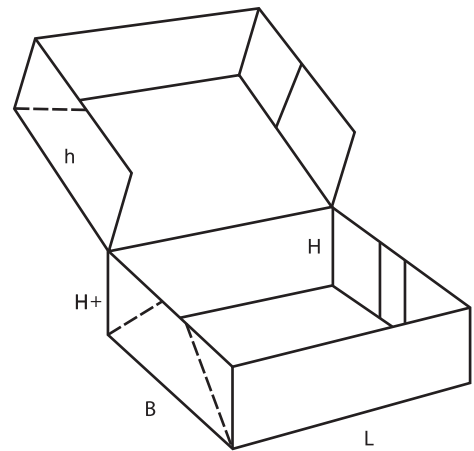
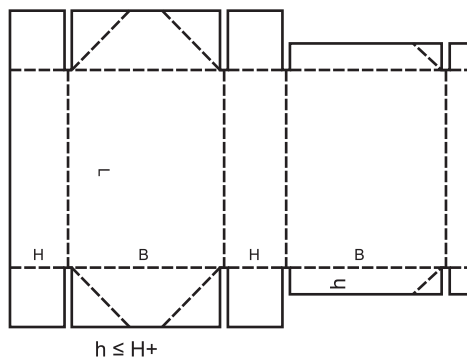

0770

M

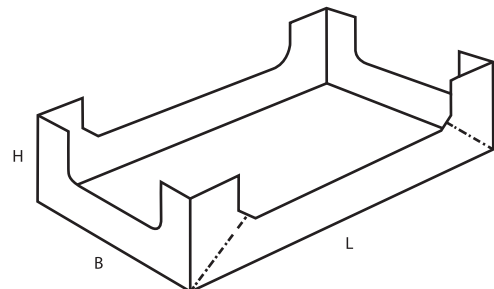
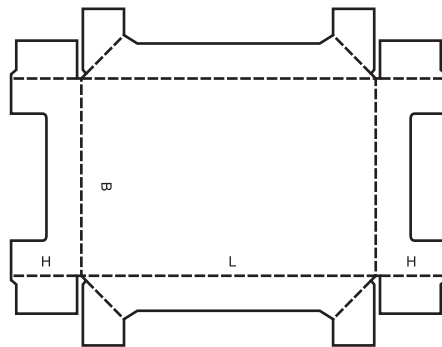

0771

M

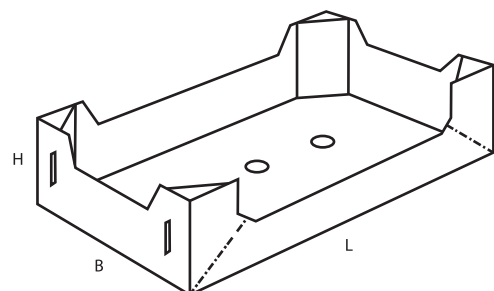
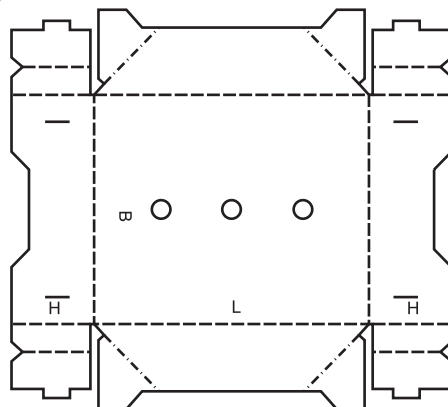

0772

M

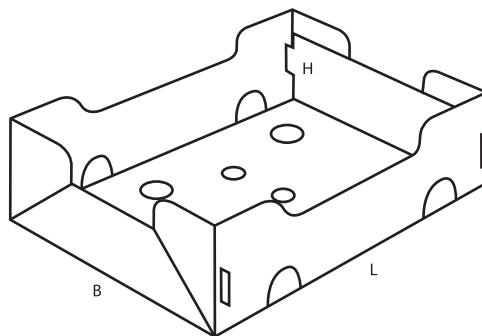
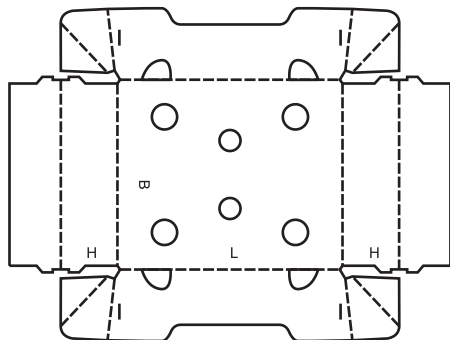

0773

M

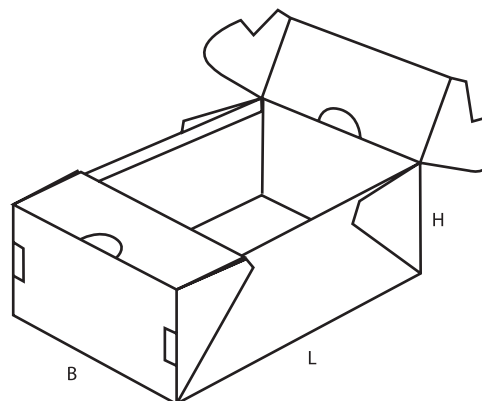
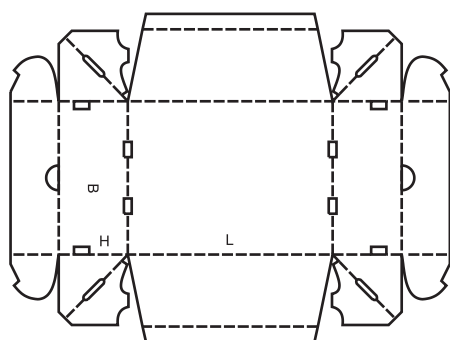

0774

M

